

# Table of Contents

## 6.0 Table of Contents

### 6.100 System description

- 6.105 Medium pipe
- 6.106 Heat insulation, casing pipe, monitoring wires
- 6.115 District heating pipe – UNO

### 6.200 Planning, design engineering

- 6.200 Pressure drop
- 6.210 Heat loss, insulation thickness 1
- 6.211 Heat loss, insulation thickness 2
- 6.212 Heat loss, insulation thickness 3
- 6.230 Pipe routing
- 6.231 Maximum installed length, L<sub>max</sub>
- 6.232 Natural fixed point, NFP
- 6.240 Maximum permitted coverage height, H<sub>max</sub>
- 6.241 Installation without pre-stressing, L<sub>max</sub>, insulation thickness 1
- 6.242 Installation without pre-stressing, L<sub>max</sub>, insulation thicknesses 2 and 3
- 6.243 Thermal pre-stressing
- 6.244 Installation with thermal pre-stressing, DN 20 - DN 300, insulation thickness 1
- 6.245 Installation with thermal pre-stressing, DN 20 - DN 300, insulation thickness 2
- 6.246 Installation with thermal pre-stressing, DN 350 - DN 500, insulation thicknesses 1 and 2
- 6.247 Installation with thermal pre-stressing, DN 20 - DN 250, insulation thickness 3
- 6.250 Impeded expansion
- 6.251 Impeded expansion; expansion up to 90 °C, DN 20 - DN 125, insulation thickness 2, permitted without pre-stressing
- 6.252 Impeded expansion; expansion up to 90 °C, DN 20 - DN 125, insulation thickness 3, permitted without pre-stressing
- 6.253 Free expansion
- 6.260 Expansion components; L, Z and U bends
- 6.261 Expansion components, transverse shift
- 6.262 Positioning of expansion pads
- 6.263 Installation guidelines, sheet 1
- 6.264 Installation guidelines, sheet 2
- 6.265 Installation guidelines, sheet 3
- 6.266 Installation guidelines, sheet 4

The design engineering worksheets are not included in this catalogue.

Please contact your BRUGG Partner in this regard.

### 6.300 Components

- 6.300 District heating pipe – UNO
- 6.304 Elbow pipe
- 6.305 Bend, with equal legs 90°
- 6.306 Bend, with equal legs 90° short
- 6.307 Bend, with equal legs 45°
- 6.308 Bend, with equal legs 45° short
- 6.310 Bend, 1.0 x 2.0 m 90°
- 6.312 T-piece, angled 45°; Insulation thickness 1
- 6.313 T-piece, angled 45°; Insulation thickness 2
- 6.314 T-piece, angled 45°; Insulation thickness 3
- 6.316 Parallel T-piece; Insulation thickness 1
- 6.317 Parallel T-piece; Insulation thickness 2

# Table of Contents

6.318	Parallel T-piece; heating, insulation thickness 3
6.320	Fixed point; thermally and electrically separated, insulation thickness 2
6.321	Reduction piece
6.322	Vent
6.323	Drainer
6.325	Fittings installed in the ground; description, installation and operating instructions
6.330	Ball valve
6.332	Ball valve with 2 vents
6.333	Ball valve with 1 vent
6.334	Ball valve for installation in the ground, installation diagram
6.335	Accessories: shut-off fitting, ball valve
6.340	Joint; shrink sleeves
6.342	Joint, shrink-on reduction sleeve/end sleeve
6.345	Brugg VISUCON
6.350	EWELCON electro-welding joint, system description
6.351	EWELCON electro-welding joint, technical data
6.352	EWELCON-S electro-welding joint
6.353	EWELCON-S electro-welding joint
6.354	Fitting bend
6.355	Wall sealing ring, pipe warning tape
6.356	Shrink-on closure
6.357	Rigid foam beam
6.360	Ring seal
6.365	Expansion pad
<b>6.400</b>	<b>Transport and storage</b>
6.403	Storage of preformed parts
6.410	Assembly foam
<b>6.500</b>	<b>Underground construction, installation</b>
6.500	Underground construction work, installation
6.501	Underground construction work, installation
6.502	Filling in the pipe trenches
6.505	House lead-in, wall seal – neoprene rubber
6.510	Installation instructions
6.515	Concrete block for fixed point, for maximum fixed point forces
6.520	Sectional drainage, sectional venting
6.525	Underground construction work for ball valve, shafts with drive-over cast cover
6.530	Tapping technology, system description
6.531	Tapping technology, dimensions and measurements
6.532	Tapping technology, weld seam preparation and structure
6.533	Tapping technology, junction branch at top with 45° PRE bend
6.534	Tapping technology, junction branch at top with 45° welded bend
6.535	Tapping technology, junction branch at bottom with 45° PRE bend
6.536	Tapping technology, junction branch at bottom with 45° welded bend
6.537	Tapping technology, junction branch at top with 90° PRE bend

# System description

## 1. General

PREMANT is the protected name for a pre-insulated steel pipe system used to transport district heat. It is a pipe system for direct installation in the ground, without channels. The system has proven its excellence over several decades and is now recognized as the industry standard for normal cases.

Depending on the purpose of use, PREMANT district heating pipe has a medium pipe made of steel, either welded, seamless or galvanized, or made of stainless steel. This makes PREMANT district heating pipe suitable to transport heating water, domestic hot water, water/glycol mixture, condensates and other fluids, but not for steam. (with observation of the temperature)

Heat insulation for PREMANT district heating pipe is performed by a rigid polyurethane foam which can withstand temperatures of up to 144 °C. PE-HD casing pipe provides external protection. All three components form one fixed unit, so this pipe system is a member of the composite pipe family.

PREMANT district heating pipe is available in three categories of insulation thickness. Depending on the dimensions, the pipe construction units can be supplied in lengths of 6 + 12 m (or 16 m). The construction units and all associated preformed parts such as bends, T-pieces and fixed points, etc., are prefabricated in the factory. The result is a modular system which is correspondingly easy to plan and install.

All the components are connected together on site with circumferential seams. Supplementary insulation of the the weld seam and the weld-on ends is provided by means of joints. The supplementary insulation work is usually carried out by system suppliers or qualified specialist companies on our behalf. During the planning phase, we offer support based on our system experience to system users who request this.

PREMANT district heating pipe, and the preformed parts and fittings, are manufactured according to the latest standards (EN 253, 448, 488 and 489).

**All the illustrations are schematic representations that do not correspond to the original components in every detail.**

## 2. Range of applications

Max. temperature for continuous operation

$T_{Bmax}$ : 144 °C (160 °C)

Max. permitted operating pressure p: 25 bar

# System description

## 1. Medium pipe

Bars: steel pipes with longitudinal or helical seam welds  
Quality: P 235 GH; EN 10220/EN 10217-2  
Standard: EN 253  
Test certificate: EN 10204 - 3.1  
Welding bevel: Wall thickness > 3.2 mm acc. to DIN 2559-1 Index 21 and 22

Preformed parts: **T-pieces** are flared, from longitudinal seam-welded steel pipes, or made of welded t-pieces acc. to EN 10253; material is the same as for straight welded pipes.  
Quality: P235GH as per; EN 10220/EN 10217  
Standard: EN 448  
Test certificate: EN 10204 - 3.1  
Welding bevel: Wall thickness > 3.2 mm acc. to DIN 2559-1 Index 21 and 22

**Bends, DN 20 - DN 200** are made of cold-bent (seamless or welded) steel pipes or with a welding elbow acc. to EN 10253.

Quality: P235GH as per; EN 10220/EN 10217  
Standard: EN 448  
Factory certificate: EN 10204-2.2  
Acceptance test certificate: EN 10204-3.1  
Welding bevel: Wall thickness > 3.2 mm acc. to DIN 2559-1 Index 21 and 22

**Bends, DN 250 - DN 1000** are made of welded bends acc. to EN 10253 with weld-on pipe ends.

Quality: P235GH  
Standard: EN 448  
Factory certificate: EN 10204-2.2  
Acceptance test certificate: EN 10204-3.1  
Welding bevel: Wall thickness > 3.2 mm acc. to DIN 2559-1 Index 21 and 22

### Note:

To ensure the longevity of PREMANT plastic sheathing pipe systems, it is important to make sure the heating water is of sufficient quality. To prevent magnetite formation (iron(II,III) oxide) and calcification in particular, the requirements of VDI 2035, AGFW FW510 and EN 12953-10 must be met.

Before commissioning, a newly-installed heat distribution network, without a heat exchanger if possible, should be circulated and suspended solids must be removed by means of a suitable filter system. This process should also be repeated after every expansion of the network or every repair.



# System description

## 2. Thermal insulation

Material: Polyurethane foam (pentane-blown), manufactured from 3 components: polyol, isocyanate and cyclopentane  
High-pressure plants are used for mixing and metering.

PUR insulation	Reference temperature °C	PREMANT value	Test standard
Compression strength	-	≥ 0.3 MPa	EN 253
Thermal conductivity	50	≤ 0.026 W/mK	DIN 52612
Percentage of closed cells	-	≥ 96 %	
Water absorption after 24 hours	-	≤ 10 %	
Ozone-depleting potential (ODP)	-	0	
Warming Potential	-	< 5	Value for C <sub>5</sub> H <sub>10</sub> from „Regulation EU 517/2014 Anx. IV“

### 2.1 Supplementary insulation

Standard: EN 489  
Execution:

- Executed by trained installation staff
- Polyurethane foam is used to foam and seal the joints
- Sealing with shrink-on sleeve or electro-welding joint
- Connecting the monitoring wires
- Installing the expansion pads, consisting of an elastic foam material which is resistant to ageing

## 3. Casing pipe

Quality: PE-HD, GM 5010 T3 or equivalent  
Standard: EN 253  
Factory certificate: EN 10204-2.2

Dimensions of PE-HD casing pipes			Dimensions of PE-HD casing pipes	
Outer ø	Min. wall thickness		Outer ø	Min. wall thickness
	Pipes	Bends/T-pieces		Pipes/Bends/T-pieces
mm	mm	mm	mm	mm
90	3.0	4.0	400	5.3
110	3.0	4.0	450	5.6
125	3.0	4.0	500	6.3
140	3.0	4.0	560	7.0
160	3.0	4.0	630	7.6
180	3.0	4.0	670	8.0
200	3.2	4.0	710	8.7
225	3.5	4.0	800	9.0
250	3.6	5.0	900	10.1
280	4.4	5.0	1000	11.2
315	4.5	5.0	1100	12.0
355	5.0	5.0	1200	12.8

## 4. Monitoring wires

Brandes system: 1 x CrNi, red, insulated and perforated, Ø 0.5 mm/0.2 mm<sup>2</sup>  
1 x Cu, green, insulated, Ø 0.8 mm / 0.5 mm<sup>2</sup>  
Nordic system: 1 x Cu blank: 1.5 mm<sup>2</sup>  
1 x Cu tinned: 1.5 mm<sup>2</sup>  
Task: Identification and location of moisture by means of resistance or pulse measurements

# District heating pipe – UNO

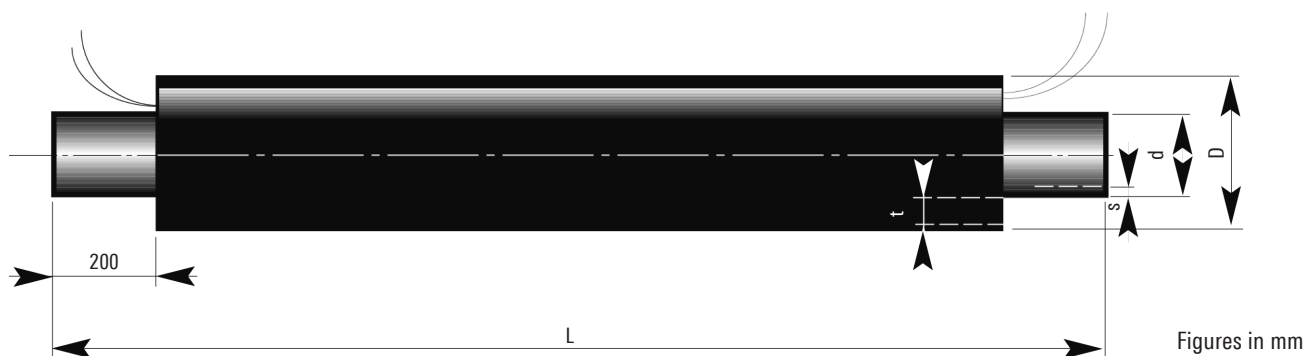

D = outer diameter of casing pipe  
 d = outer diameter of medium pipe

s = wall thickness of medium pipe  
 t = insulation thickness

## PREMANT

Nominal width DN	Steel pipe d x s mm	Insulation thickness 1		Insulation thickness 2		Insulation thickness 3		Standard length m	Volume Inner pipe l/m
		D mm	kg/m	D mm	kg/m	D mm	kg/m		
20	26.9 x 2.6	90	2.7	110	3.1	125	3.4	6	0.37
25	33.7 x 2.6	90	3.1	110	3.5	125	3.8	6	0.67
32	42.4 x 2.6	110	4.0	125	4.3	140	4.7	6 / 12	1.09
40	48.3 x 2.6	110	4.4	125	4.7	140	5.0	6 / 12	1.46
50	60.3 x 2.9	125	5.8	140	6.1	160	6.6	6 / 12	2.33
65	76.1 x 2.9	140	7.1	160	7.6	180	8.2	6 / 12	3.88
80	88.9 x 3.2	160	9.0	180	9.6	200	10.3	6 / 12	5.35
100	114.3 x 3.6	200	13.0	225	13.9	250	15.0	6 / 12 / 16	9.01
125	139.7 x 3.6	225	15.9	250	16.9	280	18.7	6 / 12 / 16	13.79
150	168.3 x 4.0	250	20.5	280	22.3	315	24.0	6 / 12 / 16	20.18
200	219.1 x 4.5	315	30.5	355	32.5	400	35.8	6 / 12 / 16	34.67
250	273.0 x 5.0	400	43.5	450	47.0	500	51.3	6 / 12 / 16	54.33
300	323.9 x 5.6	450	56.2	500	60.5	560	66.1	6 / 12 / 16	76.80
350	355.6 x 5.6	500	63.7	560	69.3	630	76.3	6 / 12 / 16	93.16
400	406.4 x 6.3	560	81.0	630	88.0	710	97.7	6 / 12 / 16	121.80
450	457.2 x 6.3	630	93.5	710	103	800	113	6 / 12 / 16	155.25
500	508.0 x 6.3	710	108	800	118	900	133	6 / 12 / 16	192.75
600	610.0 x 7.1	800	140	900	154	1000	170	6 / 12 / 16	278.80
700	711.0 x 8.0	900	180	1000	196	1100	213	6 / 12 / 16	379.37
800	813.0 x 8.8	1000	223	1100	240	1200	259	6 / 12 / 16	496.98
900	914.0 x 10.0	1100	279	1200	298	-	-	6 / 12	627.72
1000	1016.0 x 11.0	1200	337	-	-	-	-	6	776.00

We will deliver different dimensions on request.

# Pressure drop chart

Water temperature 80 °C

Surface roughness  $\epsilon = 0.045 \text{ mm}$

(1 mmWS = 9.81 Pa)

$\dot{m} \approx \frac{Q \cdot 860}{\Delta T}$	$\dot{m} =$ Flow rate in kg/h
	$Q =$ Power requirement in kW
	$\Delta T =$ Temperature difference, VL(flow)/RL(return) in °C

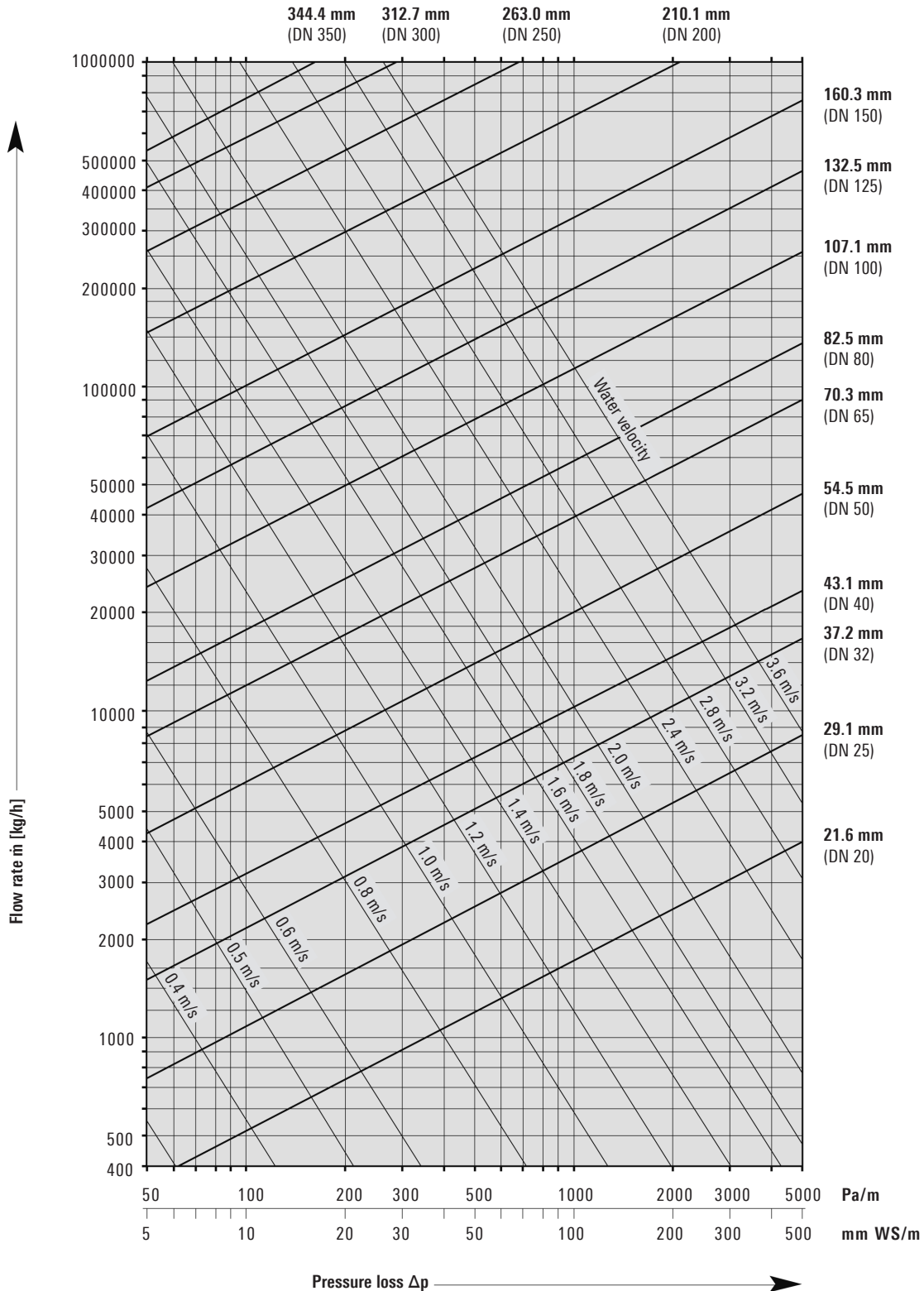

# Heat loss

Insulation thickness 1

Heat losses q [W/m] for one pipe

PREMANT	U-value W/mK	Average temperature between VL/RL $T_B$ [°C]								
		50 °C	60 °C	70 °C	80 °C	90 °C	100 °C	110 °C	120 °C	130 °C
26.9 - 90	0.1292	5.2	6.5	7.8	9.0	10.3	11.6	12.9	14.2	15.5
33.7 - 90	0.1572	6.3	7.9	9.4	11.0	12.6	14.2	15.7	17.3	18.9
42.4 - 110	0.1607	6.4	8.0	9.6	11.2	12.9	14.5	16.1	17.7	19.3
48.3 - 110	0.1843	7.4	9.2	11.1	12.9	14.7	16.6	18.4	20.3	22.1
60.3 - 125	0.2054	8.2	10.3	12.3	14.4	16.4	18.5	20.5	22.6	24.6
76.1 - 140	0.2410	9.6	12.0	14.5	16.9	19.3	21.7	24.1	26.5	28.9
88.9 - 160	0.2484	9.9	12.4	14.9	17.4	19.9	22.4	24.8	27.3	29.8
114.3 - 200	0.2599	10.4	13.0	15.6	18.2	20.8	23.4	26.0	28.6	31.2
139.7 - 225	0.3002	12.0	15.0	18.0	21.0	24.0	27.0	30.0	33.0	36.0
168.3 - 250	0.3557	14.2	17.8	21.3	24.9	28.5	32.0	35.6	39.1	42.7
219.1 - 315	0.3887	15.5	19.4	23.3	27.2	31.1	35.0	38.9	42.8	46.6
273.0 - 400	0.3779	15.1	18.9	22.7	26.5	30.2	34.0	37.8	41.6	45.3
323.9 - 450	0.4342	17.4	21.7	26.0	30.4	34.7	39.1	43.4	47.8	52.1
355.6 - 500	0.4239	17.0	21.2	25.4	29.7	33.9	38.2	42.4	46.6	50.9
406.4 - 560	0.4514	18.1	22.6	27.1	31.6	36.1	40.6	45.1	49.6	54.2
457.2 - 630	0.4548	18.2	22.7	27.3	31.8	36.4	40.9	45.5	50.0	54.6
508.0 - 710	0.4413	17.7	22.1	26.5	30.9	35.3	39.7	44.1	48.5	53.0
610.0 - 800	0.5380	21.5	26.9	32.3	37.7	43.0	48.4	53.8	59.2	64.6
711.0 - 900	0.6097	24.4	30.5	36.6	42.7	48.8	54.9	61.0	67.1	73.2
813.0 - 1000	0.6840	27.4	34.2	41.0	47.9	54.7	61.6	68.4	75.2	82.1
914.0 - 1100	0.7550	30.2	37.7	45.3	52.8	60.4	67.9	75.5	83.0	90.6
1016.0 - 1200	0.8315	33.3	41.6	49.9	58.2	66.5	74.8	83.1	91.5	99.8

Type of installation: 2-pipe, laid in the ground  
 Pipe distance:  $a = 0.20 \text{ m}$   
 Ground temperature:  $T_E = 10 \text{ °C}$   
 Coverage height:  $H = 0.8 \text{ m}$   
 Soil conductivity:  $\lambda_E = 1.2 \text{ W/mK}$   
 Conductivity of PE jacket:  $\lambda_{PE} = 0.4 \text{ W/mK}$   
 Conductivity of PUR foam:  $\lambda_{PUR} = 0.0260 \text{ W/mK}$

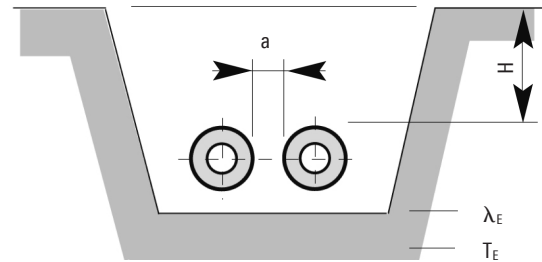

Heat loss during operation:

$$q = U \cdot (T_B - T_E) \text{ [W/m]}$$

$U$  = Heat transfer coefficient [W/mK]

$T_B$  = Average temperature between VL/RL [°C]

$T_E$  = Average ground temperature [°C]

# Heat loss

## Insulation thickness 2

Heat losses q [W/m] for one pipe										
PREMANT	U-value W/mK	Average temperature between VL/RL $T_B$ [°C]								
		50 °C	60 °C	70 °C	80 °C	90 °C	100 °C	110 °C	120 °C	130 °C
26.9 - 110	0.1110	4.4	5.5	6.7	7.8	8.9	10.0	11.1	12.2	13.3
33.7 - 110	0.1311	5.2	6.6	7.9	9.2	10.5	11.8	13.1	14.4	15.7
42.4 - 125	0.1424	5.7	7.1	8.5	10.0	11.4	12.8	14.2	15.7	17.1
48.3 - 125	0.1606	6.4	8.0	9.6	11.2	12.8	14.5	16.1	17.7	19.3
60.3 - 140	0.1794	7.2	9.0	10.8	12.6	14.4	16.1	17.9	19.7	21.5
76.1 - 160	0.2009	8.0	10.0	12.1	14.1	16.1	18.1	20.1	22.1	24.1
88.9 - 180	0.2105	8.4	10.5	12.6	14.7	16.8	18.9	21.0	23.2	25.3
114.3 - 225	0.2193	8.8	11.0	13.2	15.4	17.5	19.7	21.9	24.1	26.3
139.7 - 250	0.2530	10.1	12.7	15.2	17.7	20.2	22.8	25.3	27.8	30.4
168.3 - 280	0.2870	11.5	14.3	17.2	20.1	23.0	25.8	28.7	31.6	34.4
219.1 - 355	0.3047	12.2	15.2	18.3	21.3	24.4	27.4	30.5	33.5	36.6
273.0 - 450	0.2985	11.9	14.9	17.9	20.9	23.9	26.9	29.9	32.8	35.8
323.9 - 500	0.3412	13.6	17.1	20.5	23.9	27.3	30.7	34.1	37.5	40.9
355.6 - 560	0.3297	13.2	16.5	19.8	23.1	26.4	29.7	33.0	36.3	39.6
406.4 - 630	0.3425	13.7	17.1	20.5	24.0	27.4	30.8	34.2	37.7	41.1
457.2 - 710	0.3899	15.6	19.5	23.4	27.3	31.2	35.1	39.0	42.9	46.8
508.0 - 800	0.3357	13.4	16.8	20.1	23.5	26.9	30.2	33.6	36.9	40.3
610.0 - 900	0.3879	15.5	19.4	23.3	27.2	31.0	34.9	38.8	42.7	46.5
711.0 - 1000	0.4381	17.5	21.9	26.3	30.7	35.0	39.4	43.8	48.2	52.6
813.0 - 1100	0.4899	19.6	24.5	29.4	34.3	39.2	44.1	49.0	53.9	58.8
914.0 - 1200	0.5405	21.6	27.0	32.4	37.8	43.2	48.6	54.0	59.4	64.9

Type of installation: 2-pipe, laid in the ground  
 Pipe distance:  $a = 0.20$  m  
 Ground temperature:  $T_E = 10$  °C  
 Coverage height:  $H = 0.8$  m  
 Soil conductivity:  $\lambda_E = 1.2$  W/mK  
 Conductivity of PE jacket:  $\lambda_{PE} = 0.4$  W/mK  
 Conductivity of PUR foam:  $\lambda_{PUR} = 0.0260$  W/mK

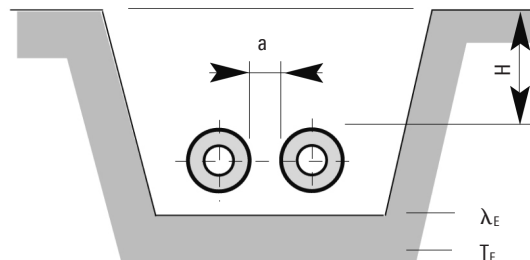

**Heat loss during operation:**

$q = U \cdot (T_B - T_E)$  [W/m]  
 $U$  = Heat transfer coefficient [W/mK]  
 $T_B$  = Average temperature between VL/RL [°C]  
 $T_E$  = Average ground temperature [°C]

# Heat loss

Insulation thickness 3

Heat losses q [W/m] for one pipe										
PREMANT	U-value W/mK	Average temperature between VL/RL T <sub>B</sub> [°C]								
		50 °C	60 °C	70 °C	80 °C	90 °C	100 °C	110 °C	120 °C	130 °C
26.9 - 125	0.1019	4.1	5.1	6.1	7.1	8.2	9.2	10.2	11.2	12.2
33.7 - 125	0.1186	4.7	5.9	7.1	8.3	9.5	10.7	11.9	13.0	14.2
42.4 - 140	0.1294	5.2	6.5	7.8	9.1	10.3	11.6	12.9	14.2	15.5
48.3 - 140	0.1442	5.8	7.2	8.7	10.1	11.5	13.0	14.4	15.9	17.3
60.3 - 160	0.1562	6.2	7.8	9.4	10.9	12.5	14.1	15.6	17.2	18.7
76.1 - 180	0.1754	7.0	8.8	10.5	12.3	14.0	15.8	17.5	19.3	21.0
88.9 - 200	0.1857	7.4	9.3	11.1	13.0	14.9	16.7	18.6	20.4	22.3
114.3 - 250	0.1930	7.7	9.7	11.6	13.5	15.4	17.4	19.3	21.2	23.2
139.7 - 280	0.2162	8.6	10.8	13.0	15.1	17.3	19.5	21.6	23.8	25.9
168.3 - 315	0.2388	9.6	11.9	14.3	16.7	19.1	21.5	23.9	26.3	28.7
219.1 - 400	0.2505	10.0	12.5	15.0	17.5	20.0	22.5	25.0	27.6	30.1
273.0 - 500	0.2514	10.1	12.6	15.1	17.6	20.1	22.6	25.1	27.7	30.2
329.0 - 560	0.2774	11.1	13.9	16.6	19.4	22.2	25.0	27.7	30.5	33.3
355.3 - 630	0.2676	10.7	13.4	16.1	18.7	21.4	24.1	26.8	29.4	32.1
406.4 - 670	0.3044	12.2	15.2	18.3	21.3	24.3	27.4	30.4	33.5	36.5
457.2 - 710	0.3435	13.7	17.2	20.6	24.0	27.5	30.9	34.4	37.8	41.2
508.0 - 900	0.2704	10.8	13.5	16.2	18.9	21.6	24.3	27.0	29.7	32.4
610.0 - 1000	0.3105	12.4	15.5	18.6	21.7	24.8	27.9	31.1	34.2	37.3
711.0 - 1100	0.3494	14.0	17.5	21.0	24.5	28.0	31.4	34.9	38.4	41.9
813.0 - 1200	0.3895	15.6	19.5	23.4	27.3	31.2	35.1	39.0	42.8	46.7

Type of installation: 2-pipe, laid in the ground  
 Pipe distance: a = 0.20 m  
 Ground temperature: T<sub>E</sub> = 10 °C  
 Coverage height: H = 0.8 m  
 Soil conductivity: λ<sub>E</sub> = 1.2 W/mK  
 Conductivity of PE jacket: λ<sub>PE</sub> = 0.4 W/mK  
 Conductivity of PUR foam: λ<sub>PUR</sub> = 0.0260 W/mK

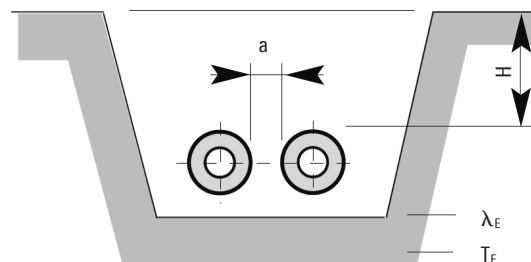

**Heat loss during operation:**  
 $q = U \cdot (T_B - T_E)$  [W/m]  
 U = Heat transfer coefficient [W/mK]  
 T<sub>B</sub> = Average temperature between VL/RL [°C]  
 T<sub>E</sub> = Average ground temperature [°C]

# Pipe routing

Pipe routing for PREMANT district heating pipe is not subject to any special requirements. In relation to the pipe, it should mainly be selected on the basis of expansion capability. In normal pipe routing, changes of direction using L-bends are the first choice for this purpose. Then come Z-bends and U-bends, which accommodate the expansion that occurs at precisely defined points.

The angular dimensions of the 'expansion bend' should not exceed 90°, otherwise substantially longer expansion limbs are needed; whenever possible, right-angled pipe routing should be the aim.



**Figure 1** Straight pipe routing between two buildings; the expansion of the district heating pipes has to be accommodated in building A or B.



**Figure 4** Straight pipe routing between two buildings, with expansion accommodated by U-bends within the pipeline.

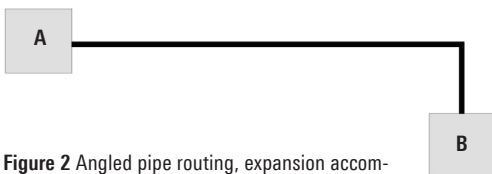

**Figure 2** Angled pipe routing, expansion accommodated by natural change of direction in the L-bend and building A.

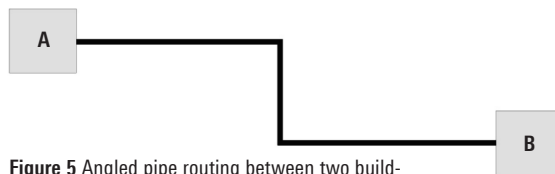

**Figure 5** Angled pipe routing between two buildings, with expansion accommodated by Z-bends within the pipeline.



**Figure 3** Straight pipe routing between two buildings, with expansion accommodated by Z-bends within the pipeline.

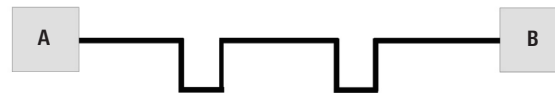

**Figure 6** Straight pipe routing, with expansion accommodated by U-bends within the pipeline.

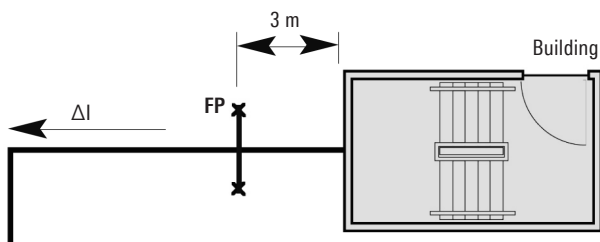

If no expansion can be accommodated in buildings, fixed points must be positioned in the building wall or approx. 3 m in front of it.

# Installation guidelines

## Sheet 1

### Positioning of branches

When positioning branches, e.g. house connection pipes on the main pipe, attention must be paid to the special features of the plastic casing pipe system. Even short connecting pipes with small dimensions are 'clamped in' by the surrounding ground, so their movement is impeded. Again, the natural fixed point is formed in the length of the connection pipe, so restoring forces act on the main pipe. The different movements and force ratios of the main pipes and the connection pipe must therefore be considered in every case.

Direct connection  
Connection pipe  $\leq 6$  m

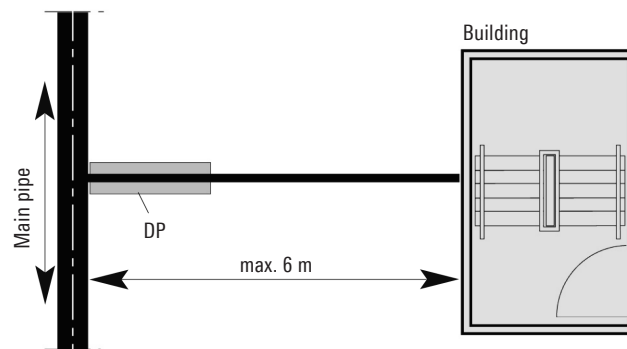

With fixed point  
Connection pipe  $> 6$  m

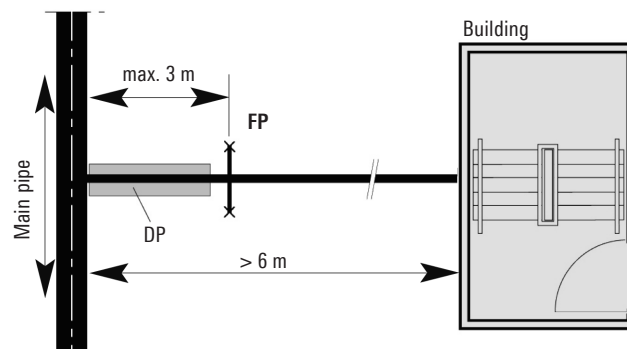

With Z-bend next to main pipe

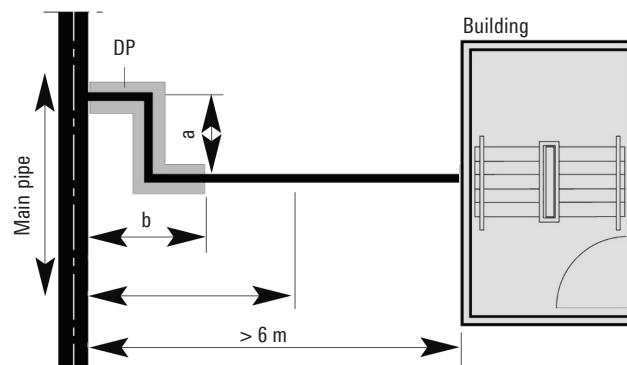

FP = fixed point  
DP = Expansion pad



# Installation guidelines

## Sheet 2

### L-bend over main pipe (parallel T-piece)

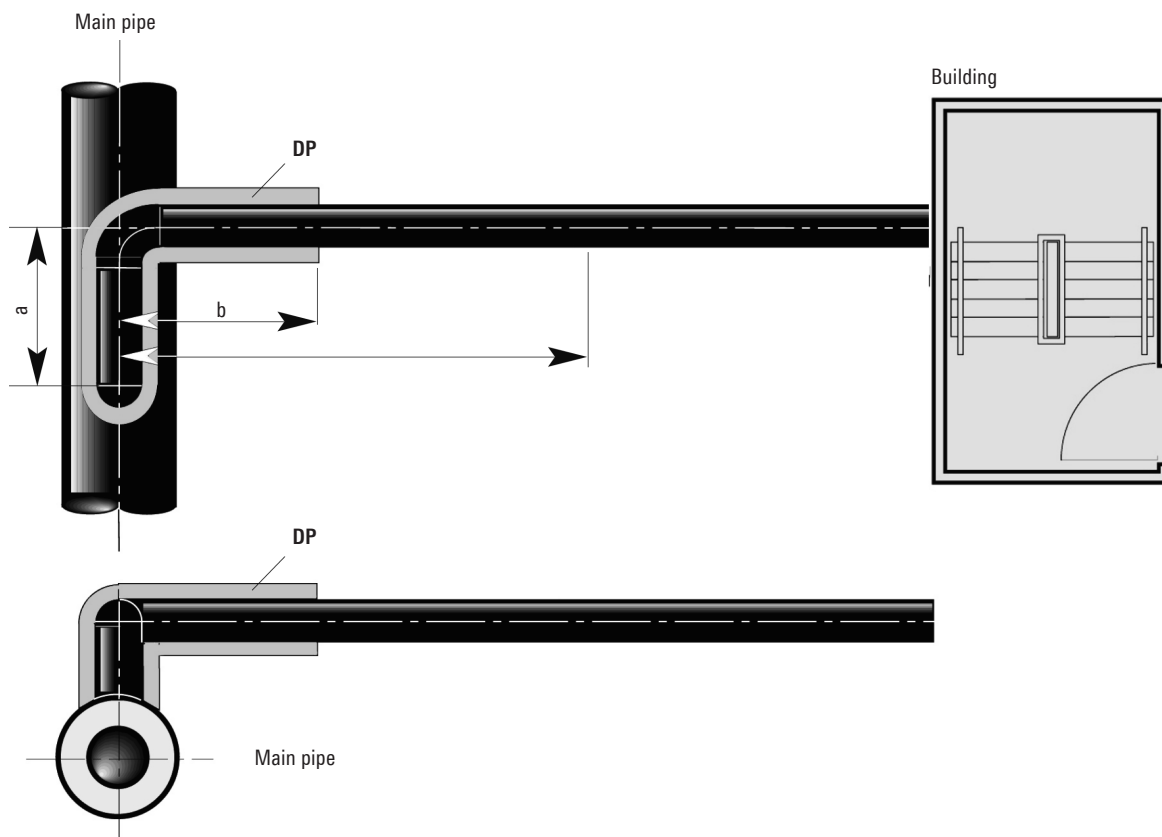

DP = expansion pad

The limb length **a** depends on the length **l**. Length **b** is based on the possible movement of the main pipe. The total length **a + b** must be surrounded with expansion pads. Expansion of the main pipe is also possible on connections in the adhesion area due to subsequent repair work, so expansion pads should also be installed as a precaution. The thickness of the expansion pads which are necessary in such cases can be reduced if the connecting pipes are still exposed and can be aligned under low stress when the main pipe is pre-stressed.

# Installation guidelines

## Sheet 3

### Pipe bends, minimum bending radius

If district heating pipes have to be laid along roads, it may be necessary to use pipe bends in order to keep close to curves. In this case, the bends can be assembled from several straight lengths of pipe. Up to an angle of 3°/5, these bends can be produced with mitre cuts but for larger angles, only preformed parts can be used.

This pipe curvature causes bending stresses in the pipe which make it mandatory to set a minimum bending radius in relation to the pipe dimension. The minimum bending radius and the resultant maximum deflection are calculated as follows:

Bending radius for elastic-plastic strain on site

DN	da mm	R <sub>min</sub> m
20	26.9	19
25	33.7	23
32	42.4	29
40	48.3	33
50	60.3	41
65	76.1	51
80	88.9	60
100	114.3	77
125	139.7	95
150	168.3	115
200	219.1	150
250	273.0	170

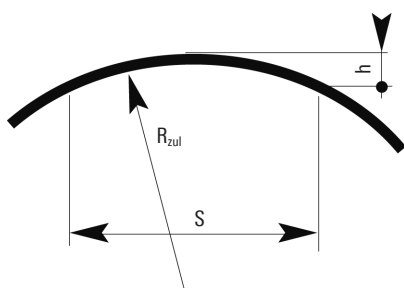

$$h = R \cdot [1 - \sqrt{1 - (s/(2 \cdot R))^2}] \text{ [m]}$$

- R<sub>permitted</sub> = minimum bending radius [m]
- S = chord length [m]
- h = maximum deflection [m]
- d<sub>a</sub> = outer diameter of steel pipe [m]

### Installation with small bends (kinks)

Sliding zone: Bends up to a maximum of 3° are allowed in mitre cuts.  
 Adhesion area: Bends up to a maximum of 5° are allowed in mitre cuts.  
 The bends must be installed without expansion pads.

### Reductions in the adhesion area

In accordance with the various stress cross-sections, there is inevitably a sudden rise in the axial compressive force progression in the reduction.

The greater compressive force in the area of the larger dimension may result in an overload in the smaller stress cross-section, as a reactive force. This can be excluded either by avoiding reductions in the adhesion area, or by positioning a fixed point on the side with the larger dimension.

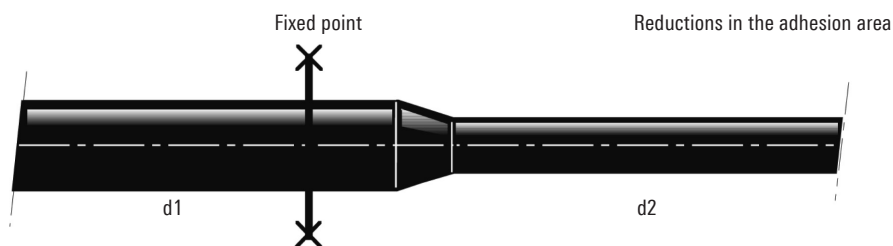

# Installation guidelines

## Sheet 4

### Changes of direction on longer pipe lengths

For  $\neq 40^\circ - 50^\circ$

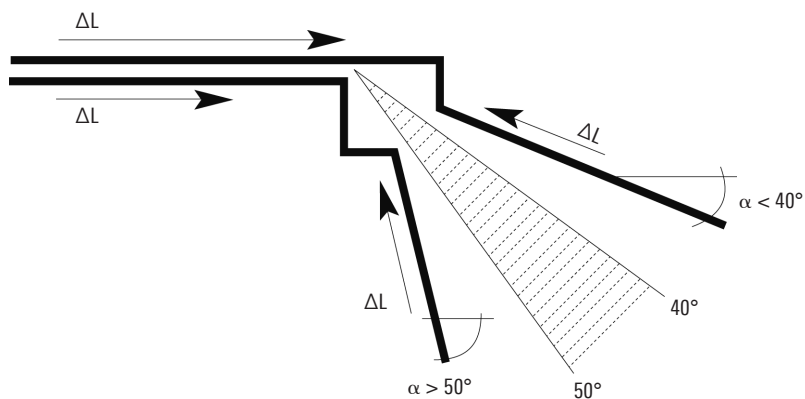

- a) For angles  $\alpha < 40^\circ$ , an additional  $90^\circ$  bend must be installed outside (see picture)
- b) For angles  $\alpha > 50^\circ$ , the additional  $90^\circ$  bend must be positioned inside (see picture)

For  $40^\circ - 50^\circ$

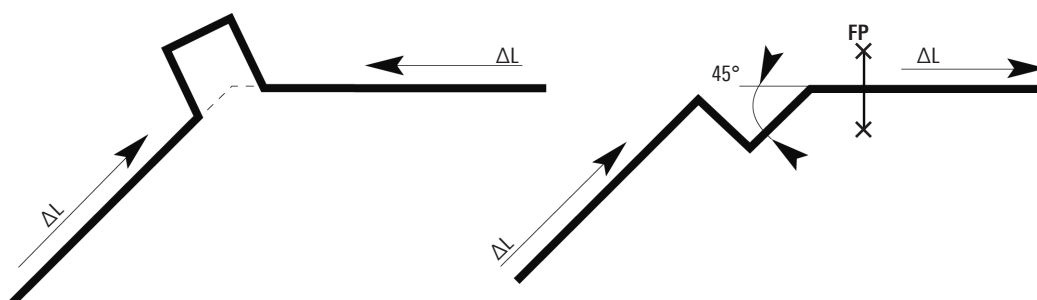

The second, newly formed angle is always larger in both cases, leading to weaker compensation.

# District heating pipe – UNO

Heating

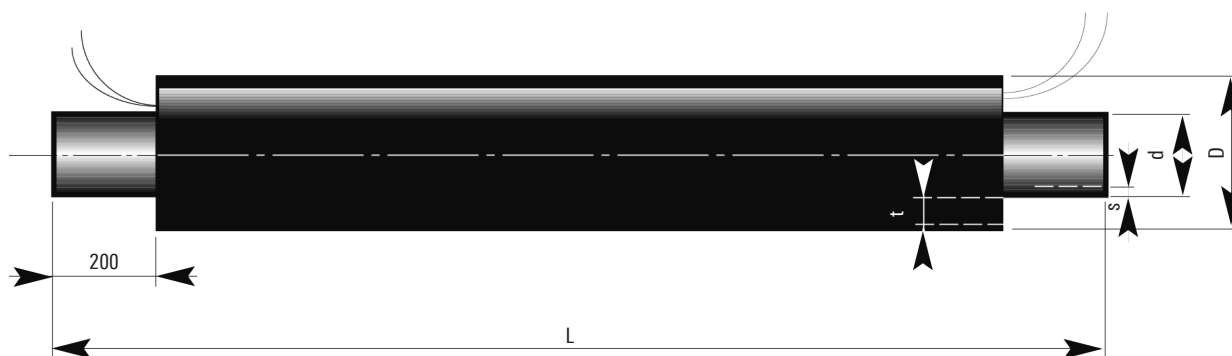

D = outer diameter of casing pipe  
d = outer diameter of medium pipe

s = wall thickness of medium pipe  
t = insulation thickness

Figures in mm

## PREMANT

Nominal	Steel pipe	Insulation thickness 1		Insulation thickness 2		Insulation thickness 3		Delivery length	Volume Inner pipe
width DN	d x s mm	D mm	kg/m	D mm	kg/m	D mm	kg/m	m	l/m
20	26.9 x 2.6	90	2.7	110	3.1	125	3.4	6	0.37
25	33.7 x 2.6	90	3.1	110	3.5	125	3.8	6	0.67
32	42.4 x 2.6	110	4.0	125	4.3	140	4.7	6 / 12	1.09
40	48.3 x 2.6	110	4.4	125	4.7	140	5.0	6 / 12	1.46
50	60.3 x 2.9	125	5.8	140	6.1	160	6.6	6 / 12	2.33
65	76.1 x 2.9	140	7.1	160	7.6	180	8.2	6 / 12	3.88
80	88.9 x 3.2	160	9.0	180	9.6	200	10.3	6 / 12	5.35
100	114.3 x 3.6	200	13.0	225	13.9	250	15.0	6 / 12 / 16	9.01
125	139.7 x 3.6	225	15.9	250	16.9	280	18.7	6 / 12 / 16	13.79
150	168.3 x 4.0	250	20.5	280	22.3	315	24.0	6 / 12 / 16	20.18
200	219.1 x 4.5	315	30.5	355	32.5	400	35.8	6 / 12 / 16	34.67
250	273.0 x 5.0	400	43.5	450	47.0	500	51.3	6 / 12 / 16	54.33
300	323.9 x 5.6	450	56.2	500	60.5	560	66.1	6 / 12 / 16	76.80
350	355.6 x 5.6	500	63.7	560	69.3	630	76.3	6 / 12 / 16	93.16
400	406.4 x 6.3	560	81.0	630	88.0	710	97.7	6 / 12 / 16	121.80
450	457.2 x 6.3	630	93.5	710	103	800	113	6 / 12 / 16	155.25
500	508.0 x 6.3	710	108	800	118	900	133	6 / 12 / 16	192.75
600	610.0 x 7.1	800	140	900	154	1000	170	6 / 12 / 16	278.80
700	711.0 x 8.0	900	180	1000	196	1100	213	6 / 12 / 16	379.37
800	813.0 x 8.8	1000	223	1100	240	1200	259	6 / 12 / 16	496.98
900	914.0 x 10.0	1100	279	1200	298	-	-	6 / 12	627.72
1000	1016.0 x 11.0	1200	337	-	-	-	-	6	776.00

# Elbow pipe



Elbow pipes are plastic casing pipes made to customer specifications and pre-insulated at the factory. Elbow pipes are produced as curved plastic casing pipes with a large radius and serve to optimise pipe routing when the direction changes.

Elbow pipes behave in the same way as straight pipes; in other words, heat expansion does not cause any bending moment. The deflection angle " $\alpha$ " of the pipe routing or the bend radius "R" must be known in order to produce elbow pipes. All elbow pipes have straight ends between 1.2 and 2.0 m due to machine-based production.

The PUR foam is subject to lateral pressure as a consequence of heat expansion and the curve of the pipe. The magnitude of this pressure must not exceed the permissible force of 0.15 MPa. The outcome of this is a maximum permissible deflection angle " $\alpha$ " or a minimum bend radius "R".

The permissible values are contained in the following table.

### Deflection angle for elbow pipes

Nominal width DN	Deflection angle bar 12 m $\alpha$ min. [°]	perm. radius $\alpha$ max.	perm. radius R min. [m]
40	10	42	16.4
50	8	38	18.1
65	5	36	19.1
80	4	34	20.2
100	4	33	20.8
125	3	29	23.7
150	3	24	28.6
200	3	20	34.4
250*	3	18	38.2
300**	3	11	62.5
350**	3	10	69.0

\* DS1 and DS2 only

\*\* DS1 only

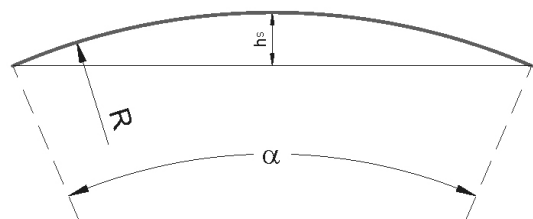

# Bend, with equal legs 90°

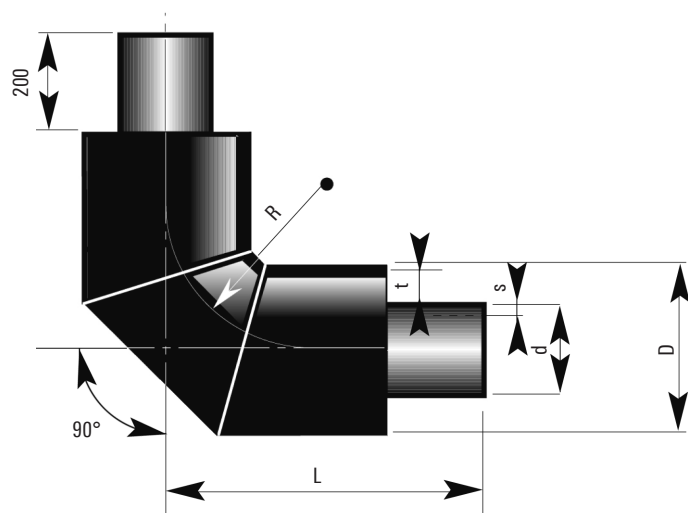

D = outer diameter of casing pipe  
 d = outer diameter of medium pipe  
 s = wall thickness of medium pipe  
 t = insulation thickness

Figures in mm

## PREMANT

Nominal width DN	Steel pipe d mm	Leg length L mm	Design DE*	Insulation thickness 1		Insulation thickness 2		Insulation thickness 3	
				D mm	kg	D mm	kg	D mm	kg
20	26.9	1000	5D	90	5.4	110	6.1	125	6.6
25	33.7	1000	5D	90	6.2	110	6.9	125	7.4
32	42.4	1000	5D	110	7.9	125	8.5	140	9.0
40	48.3	1000	5D	110	8.6	125	9.1	140	9.7
50	60.3	1000	5D	125	11.3	140	11.9	160	12.7
65	76.1	1000	5D	140	13.9	160	14.7	180	15.5
80	88.9	1000	5D	160	17.5	180	18.4	200	19.3
100	114.3	1000	5D	200	26.4	225	27.6	250	29.8
125	139.7	1000	5D**	225	30.1	250	32.5	280	34.3
150	168.3	1000	5D**	250	39.4	280	41.3	315	43.6
200	219.1	1000	5D**	315	55.9	355	58.9	400	62.8
250	273.0	1200	5D**	400	77.0	450	81.9	500	87.0
300	323.9	1000	3D	450	97.9	500	103	560	110
350	355.6	1000	3D	500	108	560	116	630	123
400	406.4	1000	3D	560	133	630	142	710	154
450	457.2	1100	3D	630	169	710	182	800	196
500	508.0	1200	3D	710	213	800	229	900	250
600	610.0	1300	3D	800	295	900	320	1000	356
700	711.0	1500	3D	900	441	1000	475	1100	506
800	813.0	1700	3D	1000	623	1100	662	1200	704

\* DE: The design of the radius is acc. EN 10253-2/3.3.

$$DE \approx \frac{2R}{d}$$

\*\* depending on availability also as 3D

# Bend, with equal legs 90°, short

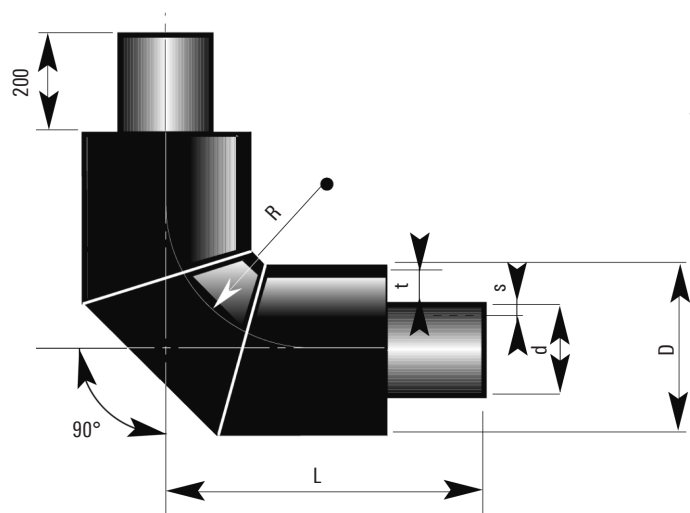

D = outer diameter of casing pipe  
 d = outer diameter of medium pipe  
 s = wall thickness of medium pipe  
 t = insulation thickness

Figures in mm

## PREMANT

Nominal width DN	Steel pipe d mm	Leg length L mm	Design DE*	Insulation thickness 1		Insulation thickness 2		Insulation thickness 3	
				D mm	kg	D mm	kg	D mm	kg
20	26.9	600	5D	90	3.0	110	3.3	125	3.6
25	33.7	600	5D	90	3.5	110	3.8	125	4.0
32	42.4	600	5D	110	4.4	125	4.7	140	4.9
40	48.3	600	5D	110	4.8	125	5.0	140	5.3
50	60.3	600	5D	125	6.3	140	6.6	160	7.0
65	76.1	650	5D	140	8.5	160	9.0	180	9.4
80	88.9	650	5D	160	10.8	180	11.3	200	11.7
100	114.3	650	5D**	200	15.6	225	16.3	250	17.6
125	139.7	650	3D	225	18.5	250	19.8	280	12.0
150	168.3	700	3D	250	26.2	280	27.4	315	17.6

\* DE: The design of the radius is acc. EN 10253-2/3.3.

$$DE \approx \frac{2R}{d}$$

\*\* depending on availability also as 3D

# Bend, with equal legs 45°

D = outer diameter of casing pipe  
 d = outer diameter of medium pipe  
 s = wall thickness of medium pipe  
 t = insulation thickness

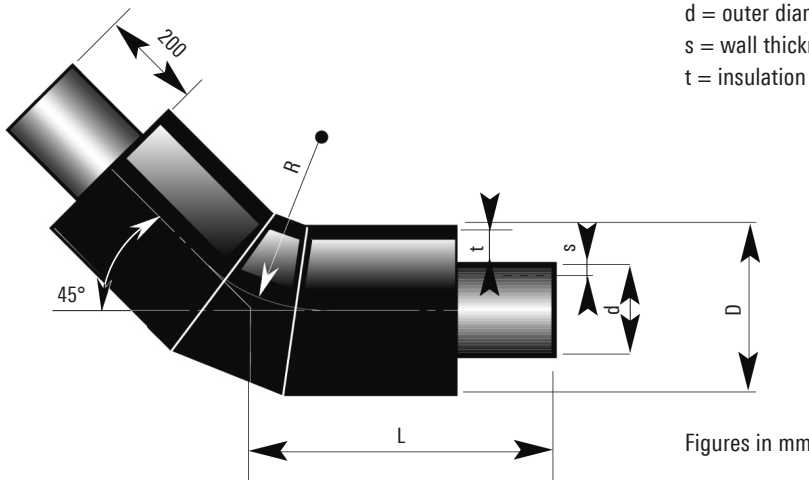

**PREMANT**

Nominal width DN	Steel pipe d mm	Leg length L mm	Design BA*	Insulation thickness 1		Insulation thickness 2		Insulation thickness 3	
				D mm	kg	D mm	kg	D mm	kg
20	26.9	1000	5D	90	5.5	110	6.2	125	6.8
25	33.7	1000	5D	90	6.3	110	7.1	125	7.6
32	42.4	1000	5D	110	8.2	125	8.7	140	9.3
40	48.3	1000	5D	110	8.8	125	9.4	140	10.0
50	60.3	1000	5D	125	11.7	140	12.3	160	13.1
65	76.1	1000	5D	140	14.4	160	15.3	180	16.1
80	88.9	1000	5D	160	18.2	180	19.1	200	20.0
100	114.3	1000	3D**	200	26.0	225	27.3	250	29.7
125	139.7	1000	3D	225	31.3	250	33.8	280	35.7
150	168.3	1000	3D	250	41.3	280	43.4	315	45.8
200	219.1	1000	3D	315	59.6	355	62.8	400	67.0
250	273.0	1000	3D	400	83.5	450	88.9	500	94.6
300	323.9	1000	3D	450	107	500	114	560	122
350	355.6	1000	3D	500	121	560	130	630	139
400	406.4	1000	3D	560	153	630	163	710	176
450	457.2	1000	3D	630	175	670	190	800	203
500	508.0	1000	3D	710	201	800	217	900	236
600	610.0	1000	3D	800	260	900	282	1000	304
700	711.0	1000	3D	900	335	1000	359	1100	382
800	813.0	1000	3D	1000	415	1100	440	1200	466

\* DE: The design of the radius is acc. EN 10253-2/3.3.

$$DE \approx \frac{2R}{d}$$

\*\* depending on availability also as 3D



# Bend, with equal legs 45°, short

D = outer diameter of casing pipe  
 d = outer diameter of medium pipe  
 s = wall thickness of medium pipe  
 t = insulation thickness

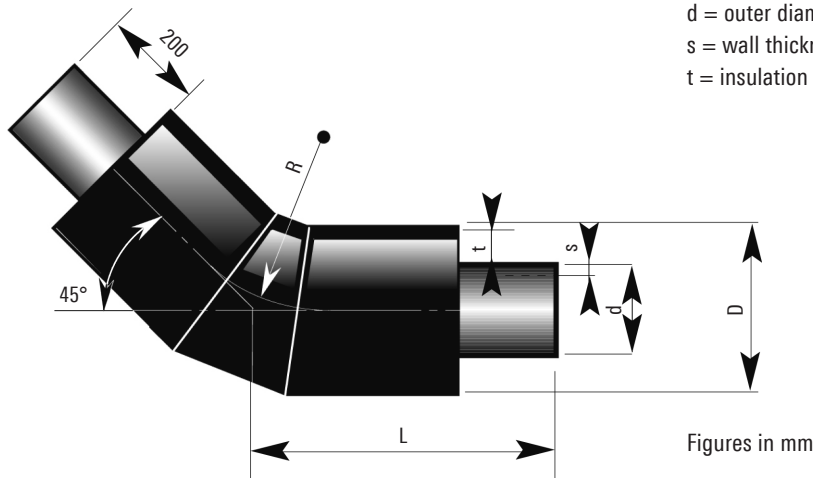

**PREMANT**

Nominal width DN	Steel pipe d mm	Leg length L mm	Design BA*	Insulation thickness 1		Insulation thickness 2		Insulation thickness 3	
				D mm	kg	D mm	kg	D mm	kg
20	26.9	500	5D	90	2.5	110	2.8	125	3.0
25	33.7	500	5D	90	2.9	110	3.2	125	3.4
32	42.4	500	5D	110	3.8	125	4.0	140	4.2
40	48.3	500	5D	110	4.1	125	4.3	140	4.5
50	60.3	500	5D	125	5.5	140	5.7	160	6.0
65	76.1	500	5D	140	6.7	160	7.1	180	7.4
80	88.9	500	5D	160	8.5	180	8.9	200	9.2
100	114.3	500 <sup>*2</sup>	5D**	200	12.2	225	12.7	250	15.2
125	139.7	500 <sup>*1</sup>	3D	225	14.8	250	17.5	280	18.3
150	168.3	550	3D	250	21.7	280	22.6	315	23.6
200	219.1	550	3D	315	31.3	355	32.7	400	34.5
250	273.0	600	3D	400	48.1	450	50.7	500	53.5
300	323.9	600	3D	450	62.3	500	65.6	560	69.3
350	355.6	650	3D	500	76.4	560	81.2	630	86.2
400	406.4	700	3D	560	104	630	110	670	114
450	457.2	700	3D	630	119	670	123	710	127
500	508.0	750	3D	710	147	800	157	900	171

<sup>\*1</sup> Insulation thickness 2 and 3 = 550 mm

<sup>\*2</sup> Insulation thickness 3 = 550 mm

\* DE: The design of the radius is acc. EN 10253-2/3.3.

$$DE \approx \frac{2R}{d}$$

\*\* depending on availability also as 3D

# Bend, 1.0 x 2.0 m, 90°

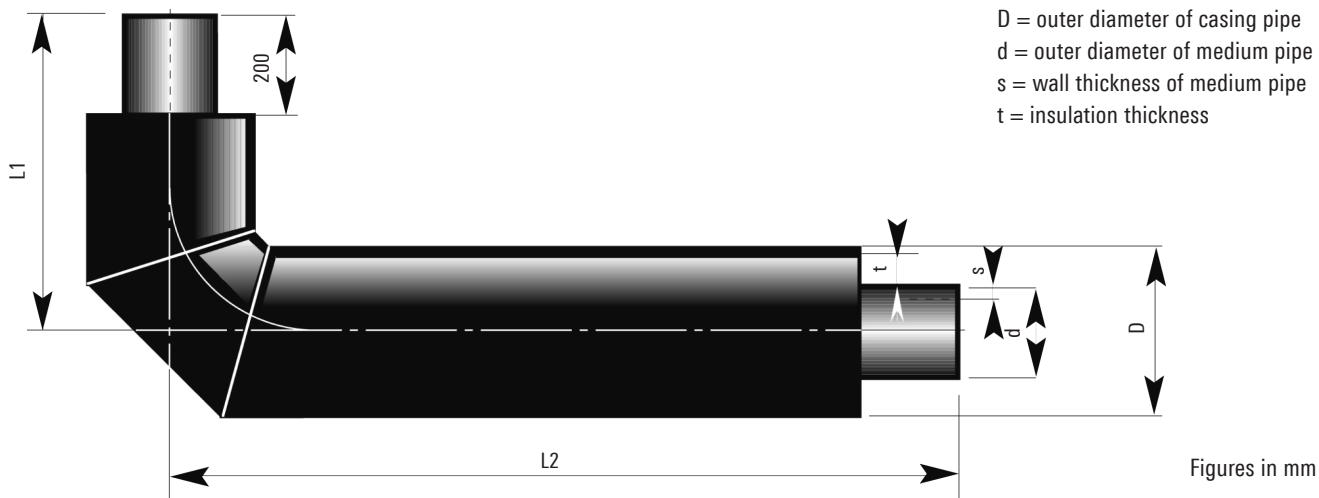

## PREMANT

Nominal width DN	Steel pipe d mm	Leg length		Design BA*	Insulation thickness 1		Insulation thickness 2		Insulation thickness 3	
		L1 mm	L2 mm		D mm	kg	D mm	kg	D mm	kg
20	26.9	1000	2000	5D	90	7.5	110	8.6	125	9.5
25	33.7	1000	2000	5D	90	8.7	110	9.8	125	10.7
32	42.4	1000	2000	5D	110	12.9	125	13.8	140	14.7
40	48.3	1000	2000	5D	110	14.1	125	15.0	140	16.0
50	60.3	1000	2000	5D	125	17.6	140	18.5	160	19.9
65	76.1	1000	2000	5D	140	21.8	160	23.2	180	24.7
80	88.9	1000	2000	5D	160	25.8	180	27.3	200	29.2
100	114.3	1000	2000	5D**	200	37.3	225	40.0	250	43.3
125	139.7	1000	2000	5D**	225	45.5	250	48.7	280	53.1
150	168.3	1000	2000	5D**	250	59.2	280	63.3	315	69.2
200	219.1	1000	2000	5D**	315	87.9	355	95.4	400	104
250	273.0	1000	2000	3D	400	126	450	138	500	151
300	323.9	1000	2000	3D	450	164	500	177	560	195
350	355.6	1000	2000	3D	500	186	560	204	630	226
400	406.4	1000	2000	3D	560	238	630	260	710	273
450	457.2	1100	2000	3D	630	275	710	293	800	315
500	508.0	1200	2000	3D	710	319	800	356	900	395

\* DE: The design of the radius is acc. EN 10253-2/3.3.

$$DE \approx \frac{2R}{d}$$

\*\* depending on availability also as 3D

# T-piece, angled 45°

Insulation thickness 1

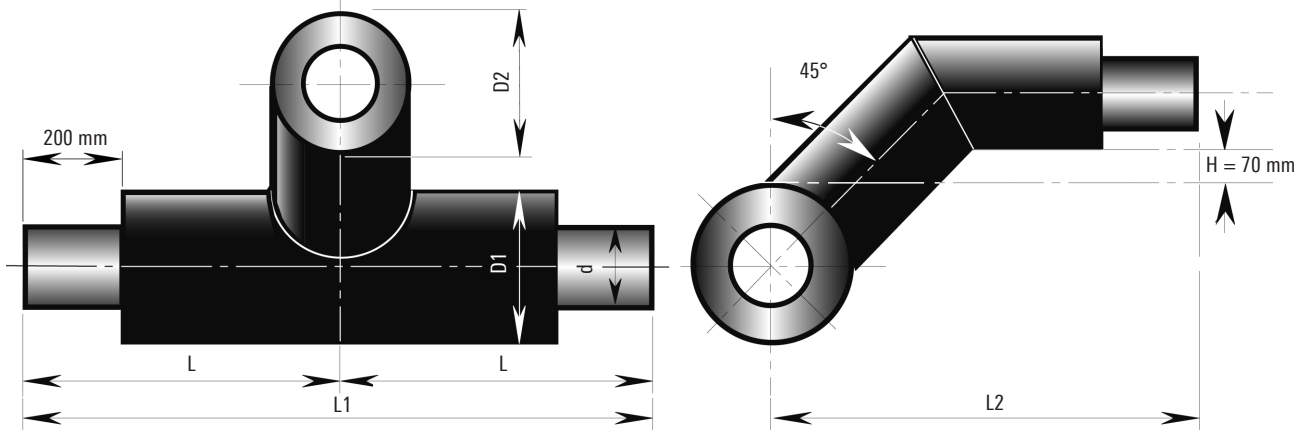

Main pipe		Branch pipe																				
DN	D1	20	25	32	40	50	65	80	100	125	150	200	250	300	350	400	450	500	600	700	800	
		D2	90	90	110	110	125	140	160	200	225	250	315	400	450	500	560	630	710	800	900	1000
20	90	L2	610																			
		L1	1000																			
25	90	L2	610	610																		
		L1	1000	1000																		
32	110	L2	620	620	630																	
		L1	1000	1000	1000																	
40	110	L2	620	620	630	630																
		L1	1000	1000	1000	1000																
50	125	L2	628	628	638	638	645															
		L1	1000	1000	1000	1000	1000															
65	140	L2	635	635	645	645	653	660														
		L1	1000	1000	1000	1000	1000	1000														
80	160	L2	645	645	655	655	663	670	680													
		L1	1000	1000	1000	1000	1000	1000	1000													
100	200	L2	665	765	675	675	683	690	700	720												
		L1	1000	1000	1000	1000	1000	1000	1000	1200												
125	225	L2	678	778	688	688	695	703	713	733	745											
		L1	1000	1000	1000	1000	1000	1000	1000	1200	1200											
150	250	L2	690	790	700	700	708	715	725	745	758	820										
		L1	1000	1000	1000	1000	1000	1000	1000	1200	1200	1200										
200	315	L2	723	723	733	733	740	748	758	778	790	853	935									
		L1	1000	1000	1000	1000	1000	1000	1000	1200	1200	1200	1200									
250	400	L2	765	765	775	775	783	790	800	820	833	895	978	1070								
		L1	1000	1000	1000	1000	1000	1000	1000	1200	1200	1200	1200	1400								
300	450	L2		890	800	800	808	815	825	845	858	920	1003	1095	1120							
		L1		1000	1000	1000	1000	1000	1000	1200	1200	1200	1200	1400	1500							
350	500	L2				825	833	840	850	870	883	945	1028	1120	1145	1220						
		L1				1000	1000	1000	1000	1200	1200	1200	1200	1400	1500	1600						
400	560	L2					863	870	880	900	913	975	1058	1150	1175	1250	1330					
		L1					1000	1000	1000	1200	1200	1200	1200	1400	1500	1600	1600					
450	630	L2							915	935	948	1010	1093	1185	1210	1285	1365	1400				
		L1							1000	1200	1200	1200	1200	1400	1500	1600	1600	1800				
500	710	L2								975	988	1050	1133	1225	1250	1325	1405	1440	1530			
		L1								1200	1200	1200	1200	1400	1500	1600	1600	1800	1800			
600	800	L2									1033	1095	1178	1270	1295	1370	1450	1485	1575	1670		
		L1									1200	1200	1500	1500	1600	1800	1800	1800	1800	1900		
700	900	L2										1145	1228	1320	1345	1420	1500	1535	1625	1720	1820	
		L1										1200	1500	1500	1800	1800	1800	1800	1800	1900	2000	
800	1000	L2											1278	1370	1395	1470	1550	1585	1675	1770	1870	1970
		L1											1500	1500	1800	1800	1800	1800	1800	1900	2000	2100

$$L = \frac{1}{2} L1$$

statically unfavourable

Larger dimensions can be supplied on request.

Figures in mm

# T-piece, angled 45°

Insulation thickness 2

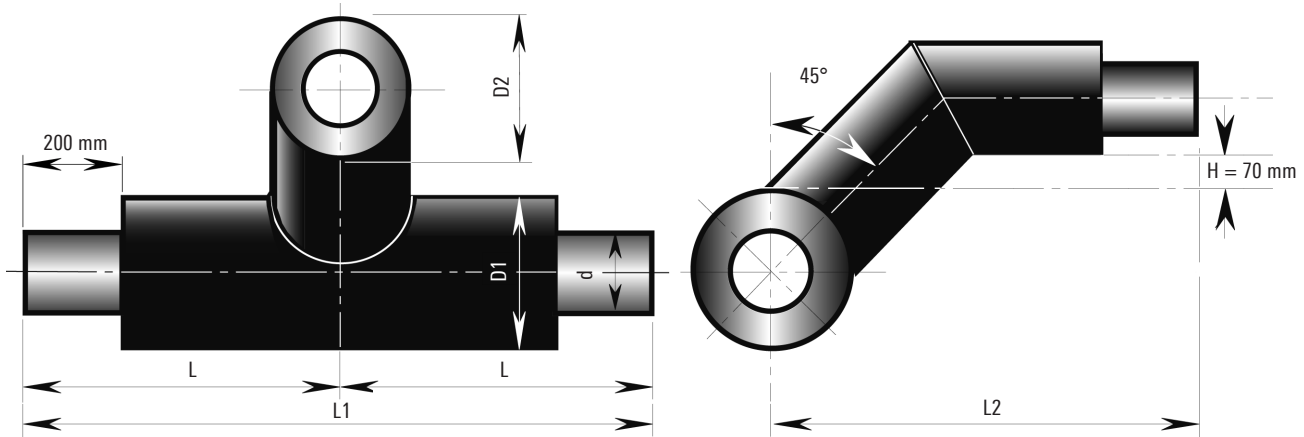

Main pipe		Branch pipe																				
DN	D1	20	25	32	40	50	65	80	100	125	150	200	250	300	350	400	450	500	600	700	800	
		D2	110	110	125	125	140	160	180	225	250	280	355	450	500	560	630	710	800	900	1000	1100
20	110	L2	630																			
		L1	1000																			
25	110	L2	630	630																		
		L1	1000	1000																		
32	125	L2	638	638	645																	
		L1	1000	1000	1000																	
40	125	L2	638	638	645	645																
		L1	1000	1000	1000	1000																
50	140	L2	645	645	653	653	660															
		L1	1000	1000	1000	1000	1000															
65	160	L2	655	655	663	663	670	680														
		L1	1000	1000	1000	1000	1000	1000														
80	180	L2	665	665	673	673	680	690	700													
		L1	1000	1000	1000	1000	1000	1000	1000													
100	225	L2	688	688	695	695	703	713	723	745												
		L1	1000	1000	1000	1000	1000	1000	1000	1200												
125	250	L2	700	700	708	708	715	725	735	758	770											
		L1	1000	1000	1000	1000	1000	1000	1000	1200	1200											
150	280	L2	715	715	723	723	730	740	750	773	785	850										
		L1	1000	1000	1000	1000	1000	1000	1000	1200	1200	1200										
200	355	L2	753	753	760	760	768	778	788	810	823	888	975									
		L1	1000	1000	1000	1000	1000	1000	1000	1200	1200	1200	1200									
250	450	L2	800	800	808	808	815	825	835	858	870	935	1023	1120								
		L1	1000	1000	1000	1000	1000	1000	1000	1200	1200	1200	1200	1400								
300	500	L2		825	833	833	840	850	860	883	895	960	1048	1145	1170							
		L1		1000	1000	1000	1000	1000	1000	1200	1200	1200	1200	1400	1500							
350	560	L2				863	870	880	890	913	925	990	1078	1175	1200	1280						
		L1				1000	1000	1000	1000	1200	1200	1200	1200	1400	1500	1600						
400	630	L2					905	915	925	948	960	1025	1113	1210	1235	1315	1400					
		L1					1000	1000	1000	1200	1200	1200	1200	1400	1500	1600	1600					
450	710	L2							945	968	980	1045	1133	1230	1255	1335	1420	1440				
		L1							1000	1200	1200	1200	1200	1400	1500	1600	1600	1800				
500	800	L2								1033	1045	1110	1198	1295	1320	1400	1485	1505	1620			
		L1								1200	1200	1200	1200	1400	1500	1600	1600	1800	1800			
600	900	L2									1095	1160	1248	1345	1370	1450	1535	1555	1670	1770		
		L1									1200	1200	1500	1500	1600	1800	1800	1800	1800	1900		
700	1000	L2										1210	1298	1395	1420	1500	1585	1605	1720	1820	1920	
		L1										1200	1500	1500	1800	1800	1800	1800	1800	1800	1900	2000
800	1100	L2											1348	1445	1470	1550	1635	1655	1770	1870	1970	2070
		L1											1500	1500	1800	1800	1800	1800	1800	1900	2000	2100

$$L = \frac{1}{2} L1$$

statically unfavourable

Larger dimensions can be supplied on request.

Figures in mm

# T-piece, angled 45°

Insulation thickness 3

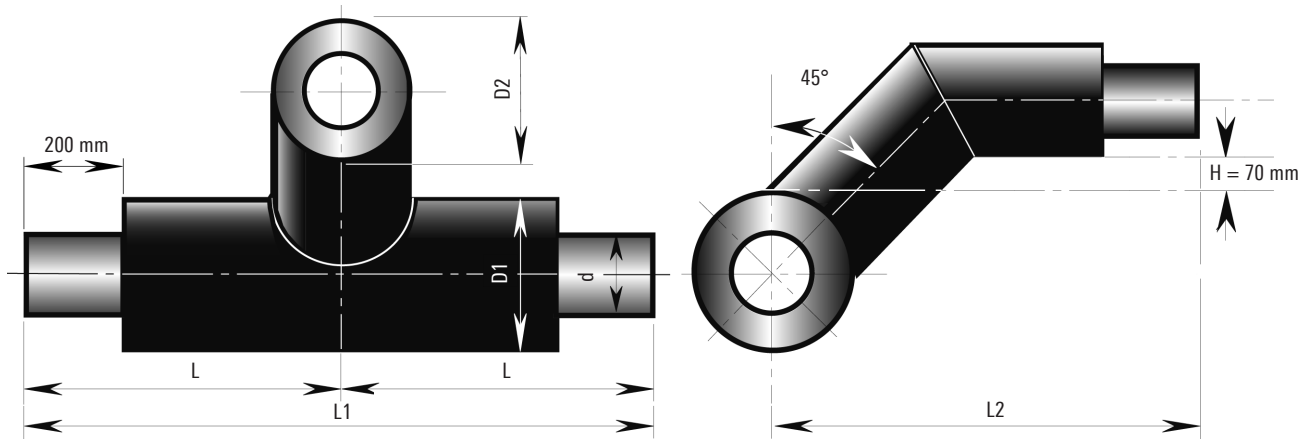

Main pipe		Branch pipe																					
DN	D1	DN	20	25	32	40	50	65	80	100	125	150	200	250	300	350	400	450	500	600	700	800	
		D2	125	125	140	140	160	180	200	250	280	315	400	500	560	630	710	800	900	1000	1100	1200	
20	125	L2	645																				
		L1	1000																				
25	125	L2	645	645																			
		L1	1000	1000																			
32	140	L2	653	653	660																		
		L1	1000	1000	1000																		
40	140	L2	653	653	660	660																	
		L1	1000	1000	1000	1000																	
50	160	L2	663	663	670	670	680																
		L1	1000	1000	1000	1000	1000																
65	180	L2	673	673	680	680	690	700															
		L1	1000	1000	1000	1000	1000	1000															
80	200	L2	683	683	690	690	700	710	720														
		L1	1000	1000	1000	1000	1000	1000	1000														
100	250	L2	708	708	715	715	725	735	745	770													
		L1	1000	1000	1000	1000	1000	1000	1000	1200													
125	280	L2	723	723	730	730	740	750	760	785	800												
		L1	1000	1000	1000	1000	1000	1000	1000	1200	1200												
150	315	L2	740	740	748	748	758	768	778	803	818	885											
		L1	1000	1000	1000	1000	1000	1000	1000	1200	1200	1200											
200	400	L2	783	783	790	790	800	810	820	845	860	928	1020										
		L1	1000	1000	1000	1000	1000	1000	1000	1200	1200	1200	1200										
250	500	L2	833	833	840	840	850	860	870	895	910	978	1070	1170									
		L1	1000	1000	1000	1000	1000	1000	1000	1200	1200	1200	1200	1400									
300	560	L2		863	870	870	880	890	900	925	940	1008	1100	1200	1230								
		L1		1000	1000	1000	1000	1000	1000	1200	1200	1200	1200	1400	1500								
350	630	L2				905	906	925	935	960	975	1043	1135	1235	1265	1350							
		L1				1000	1000	1000	1000	1200	1200	1200	1200	1400	1500	1600							
400	710	L2					935	945	955	980	995	1063	1155	1255	1285	1370	1440						
		L1					1000	1000	1000	1200	1200	1200	1200	1400	1500	1600	1600						
450	800	L2								975	1000	1015	1083	1175	1275	1305	1390	1460	1480				
		L1								1000	1200	1200	1200	1200	1400	1500	1600	1600	1800				
500	900	L2								1095	1110	1178	1270	1370	1400	1485	1555	1575	1720				
		L1								1200	1200	1200	1200	1400	1500	1600	1600	1800	1800				
600	1000	L2											1160	1228	1320	1420	1450	1535	1605	1625	1770	1870	
		L1											1200	1200	1500	1500	1600	1800	1800	1800	1800	1900	
700	1100	L2											1278	1370	1470	1500	1585	1655	1675	1820	1920	2020	
		L1											1200	1500	1500	1800	1800	1800	1800	1800	1800	1900	2000
800	1200	L2												1420	1520	1550	1635	1705	1725	1870	1970	2070	2170
		L1												1500	1500	1800	1800	1800	1800	1800	1900	2000	2100

$$L = \frac{1}{2} L1$$

statically unfavourable

Larger dimensions can be supplied on request.

Figures in mm

# Parallel T-piece

Insulation thickness 1

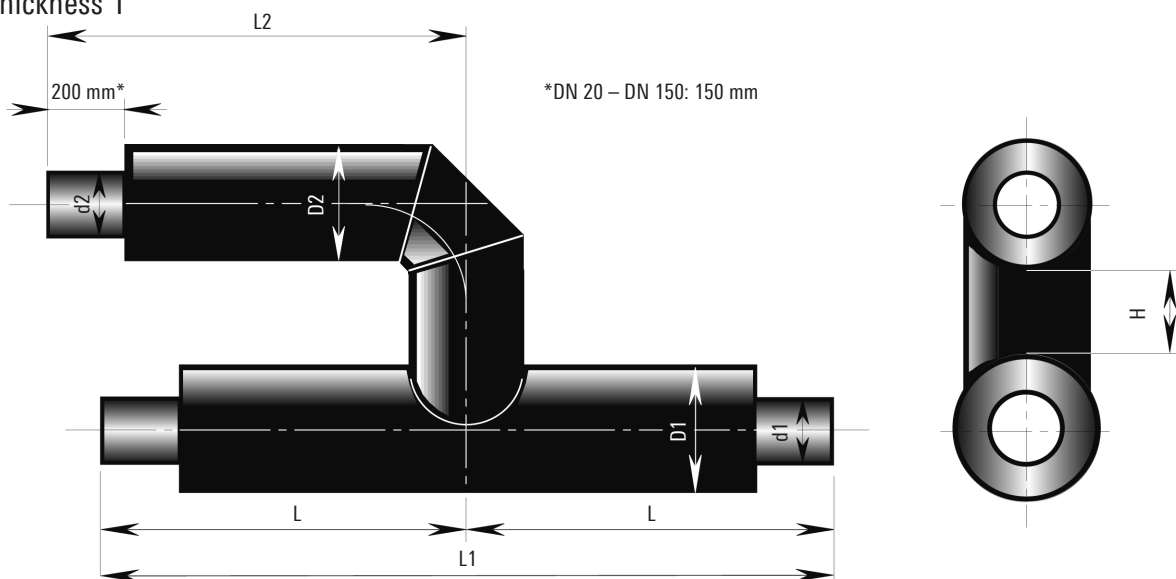

Main pipe		Branch pipe																				
DN	D1	20	25	32	40	50	65	80	100	125	150	200	250	300	350	400	450	500	600	700	800	
		D2																				
		L2																				
20	90	H L1	120 1000																			
25	90	H L1	120 1000	120 1000																		
32	110	H L1	120 1000	120 1000	120 1000																	
40	110	H L1	120 1000	120 1000	120 1000	120 1000																
50	125	H L1	120 1000	120 1000	120 1000	120 1000	120 1000															
65	140	H L1	120 1000	120 1000	120 1000	120 1000	120 1000	120 1000														
80	160	H L1	120 1000	120 1000	120 1000	120 1000	120 1000	120 1000	120 1000													
100	200	H L1	120 1000	120 1000	120 1000	120 1000	120 1000	120 1000	120 1200													
125	225	H L1	120 1000	120 1000	120 1000	120 1000	120 1000	120 1000	120 1200	140 1200												
150	250	H L1	120 1000	120 1000	120 1000	120 1000	120 1000	120 1000	120 1200	140 1200	122 1200											
200	315	H L1	120 1000	120 1000	120 1000	120 1000	120 1000	120 1000	120 1200	120 1200	164 1200	168 1200										
250	400	H L1		120 1000	120 1000	120 1000	120 1000	120 1000	120 1200	120 1200	130 1200	151 1200	197 1400									
300	450	H L1			120 1000	120 1000	120 1000	120 1000	120 1200	120 1200	147 1200	152 1200	197 1400	261 1500								
350	500	H L1				120 1000	120 1000	120 1000	120 1200	120 1200	140 1200	146 1200	188 1400	252 1500	312 1600							
400	560	H L1					120 1000	120 1200	120 1200	120 1200	140 1200	140 1200	184 1400	247 1500	308 1600	355 1600						
450	630	H L1						120 1200	120 1200	120 1200	140 1200	175 1200	238 1400	298 1500	345 1600	399 1800						
500	710	H L							120 1200	120 1200	140 1200	170 1400	180 1500	223 1600	284 1600	331 1800	384 1800	433 1800				
600	800	H L1			statically unfavourable						140 1200	170 1500	215 1500	229 1600	289 1800	336 1800	390 1800	439 1800	546 1900			
700	900	H L1									170 1500	215 1500	280 1800	290 1800	337 1800	391 1800	440 1800	572 1900	688 2000			
800	1000	H L1									170 1500	215 1500	280 1800	291 1800	338 1800	392 1800	440 1800	573 1900	689 2000	816 2100		

$$L = \frac{1}{2} L1$$

statically unfavourable

Larger dimensions can be supplied on request.

Figures in mm

# Parallel T-piece

Insulation thickness 2

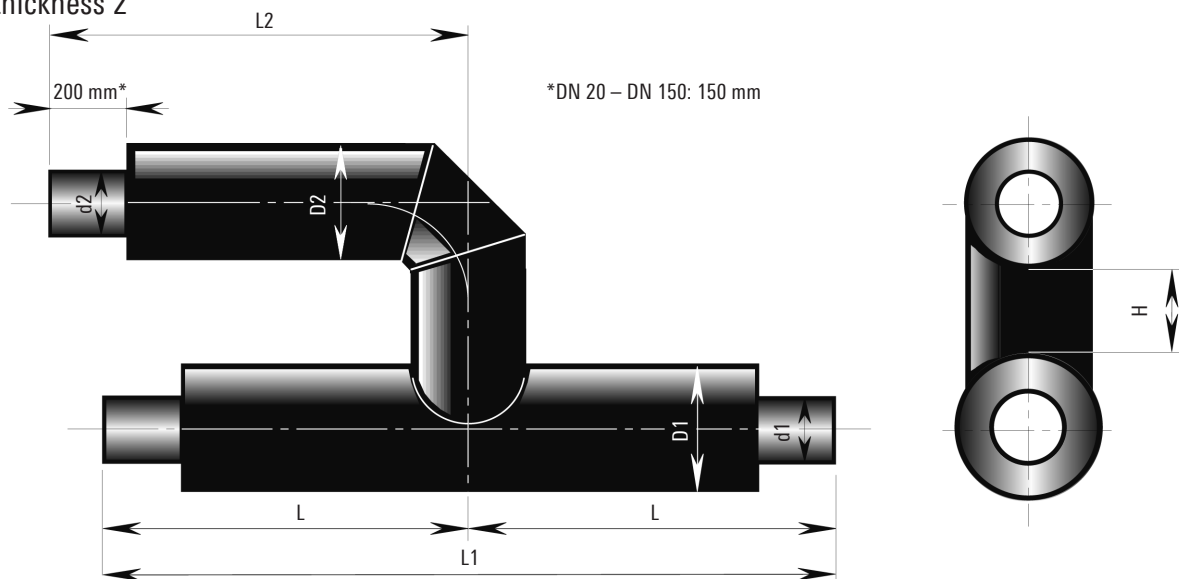

Main pipe		Branch pipe																			
DN	D1	20	25	32	40	50	65	80	100	125	150	200	250	300	350	400	450	500	600	700	800
		D2	110	125	140	160	180	225	250	280	355	450	500	560	630	710	800	900	1000	1100	
		L2	450	460	480	480	500	510	510	530	570	700	750	850	1000	1000	1100	1200	1300	1500	1700
20	110	H	120																		
		L1	1000																		
25	110	H	120	120																	
		L1	1000	1000																	
32	125	H	120	120	120																
		L1	1000	1000	1000																
40	125	H	120	120	120	120															
		L1	1000	1000	1000	1000															
50	140	H	120	120	120	120	120														
		L1	1000	1000	1000	1000	1000														
65	160	H	120	120	120	120	120	120													
		L1	1000	1000	1000	1000	1000	1000													
80	180	H	120	120	120	120	120	120	120												
		L1	1000	1000	1000	1000	1000	1000	1000												
100	225	H	120	120	120	120	120	120	120	120											
		L1	1000	1000	1000	1000	1000	1000	1000	1200											
125	250	H	120	120	120	120	120	120	120	120	130										
		L1	1000	1000	1000	1000	1000	1000	1000	1200	1200										
150	280	H	120	120	120	120	120	120	120	120	130	141									
		L1	1000	1000	1000	1000	1000	1000	1000	1200	1200	1200									
200	355	H	120	120	120	120	120	120	120	120	130	140	178								
		L1	1000	1000	1000	1000	1000	1000	1000	1200	1200	1200	1200								
250	450	H		120	120	120	120	120	120	120	130	140	160	200							
		L1		1000	1000	1000	1000	1000	1000	1200	1200	1200	1200	1400							
300	500	H				120	120	120	120	120	130	140	160	197	261						
		L1				1000	1000	1000	1000	1200	1200	1200	1200	1400	1500						
350	560	H				120	120	120	120	120	130	140	160	200	197	253					
		L1				1000	1000	1000	1000	1200	1200	1200	1200	1400	1500	1600					
400	630	H						120	120	130	140	160	200	237	294	285					
		L1						1000	1200	1200	1200	1200	1400	1500	1600	1600					
450	710	H							120	130	140	160	200	243	300	340	359				
		L1							1200	1200	1200	1200	1400	1500	1600	1600	1800				
500	800	H								130	140	160	200	198	255	296	364	433			
		L1								1200	1200	1200	1400	1500	1600	1600	1800	1800			
600	900	H									140	160	200	204	260	301	320	389	446		
		L1									1200	1500	1500	1600	1800	1800	1800	1800	1900		
700	1000	H										160	190	205	252	321	390	472	588		
		L1										1500	1500	1800	1800	1800	1800	1800	1900	2000	
800	1100	H											160	190	204	247	253	322	390	473	589
		L1											1500	1500	1800	1800	1800	1800	1900	2000	2100

$$L = \frac{1}{2} L1$$

statically unfavourable

Larger dimensions can be supplied on request.

Figures in mm

# Parallel T-piece

Insulation thickness 3

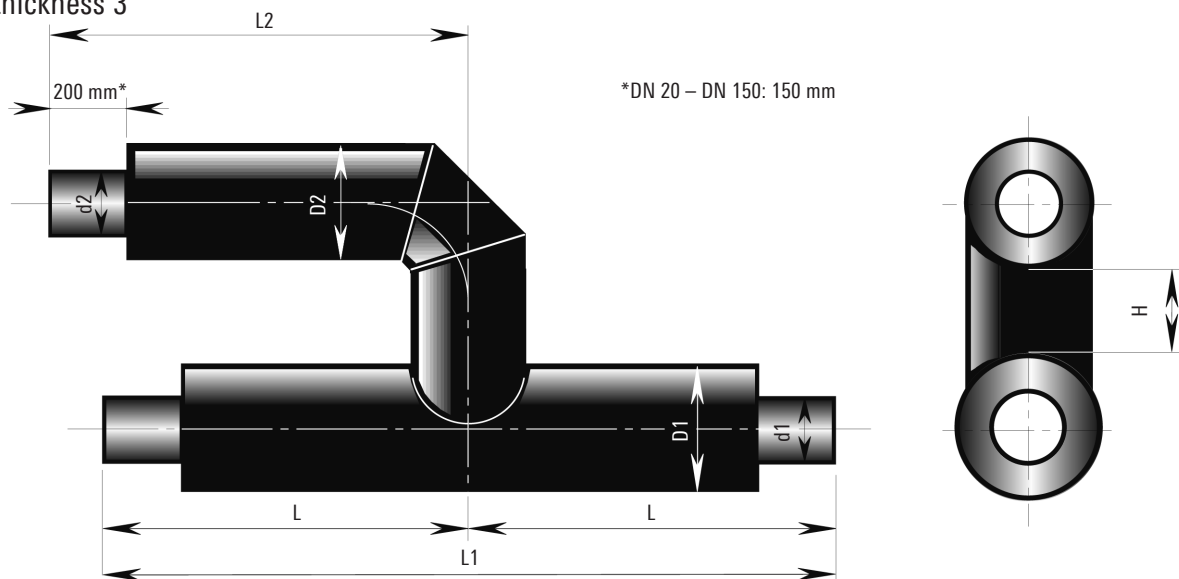

Main pipe		Branch pipe																					
DN	D1	H	20	25	32	40	50	65	80	100	125	150	200	250	300	350	400	450	500	600	700	800	
			D2	D2	D2	D2	D2	D2	D2	D2	D2	D2	D2	D2	D2	D2	D2	D2	D2	D2	D2	D2	D2
			L2	L2	L2	L2	L2	L2	L2	L2	L2	L2	L2	L2	L2	L2	L2	L2	L2	L2	L2	L2	L2
20	125	H	120																				
		L1	1000																				
25	125	H	120	120																			
		L1	1000	1000																			
32	140	H	120	120	120																		
		L1	1000	1000	1000																		
40	140	H	120	120	120	120																	
		L1	1000	1000	1000	1000																	
50	160	H	120	120	120	120	120																
		L1	1000	1000	1000	1000	1000																
65	180	H	120	120	120	120	120	120															
		L1	1000	1000	1000	1000	1000	1000															
80	200	H	120	120	120	120	120	120	120														
		L1	1000	1000	1000	1000	1000	1000	1000														
100	250	H	120	120	120	120	120	120	120	130													
		L1	1000	1000	1000	1000	1000	1000	1000	1200													
125	280	H	120	120	120	120	120	120	120	130	130												
		L1	1000	1000	1000	1000	1000	1000	1000	1200	1200												
150	315	H	120	120	120	120	120	120	120	130	130	130											
		L1	1000	1000	1000	1000	1000	1000	1000	1200	1200	1200											
200	400	H	120	120	120	120	120	120	120	130	130	130	133										
		L1	1000	1000	1000	1000	1000	1000	1000	1200	1200	1200	1200										
250	500	H		120	120	120	120	120	120	130	130	130	130	147									
		L1		1000	1000	1000	1000	1000	1000	1200	1200	1200	1200	1400									
300	560	H				120	120	120	120	130	130	130	130	142	151								
		L1				1000	1000	1000	1000	1200	1200	1200	1200	1400	1500								
350	630	H					120	120	120	130	130	130	130	130	132	183							
		L1					1000	1000	1000	1200	1200	1200	1200	1400	1500	1600							
400	710	H							120	130	130	130	130	130	137	189	245						
		L1							1000	1200	1200	1200	1200	1400	1500	1600	1600						
450	800	H								130	130	130	130	130	143	194	250	319					
		L1								1200	1200	1200	1200	1400	1500	1600	1600	1800					
500	900	H									130	130	130	130	173	175	231	299	343				
		L1									1200	1200	1200	1400	1500	1600	1600	1800	1800				
600	1000	H										130	130	130	140	175	181	250	294	346			
		L1										1200	1500	1500	1600	1800	1800	1800	1800	1900			
700	1100	H											130	130	140	176	182	251	295	372	488		
		L1											1500	1500	1800	1800	1800	1800	1800	1900	2000		
800	1200	H												130	130	140	177	183	252	295	373	489	616
		L1												1500	1500	1800	1800	1800	1800	1900	2000	2100	

$$L = \frac{1}{2} L1$$

statically unfavourable

Larger dimensions can be supplied on request.

Figures in mm



# Fixed point

Thermally and electrically separated (all insulations)

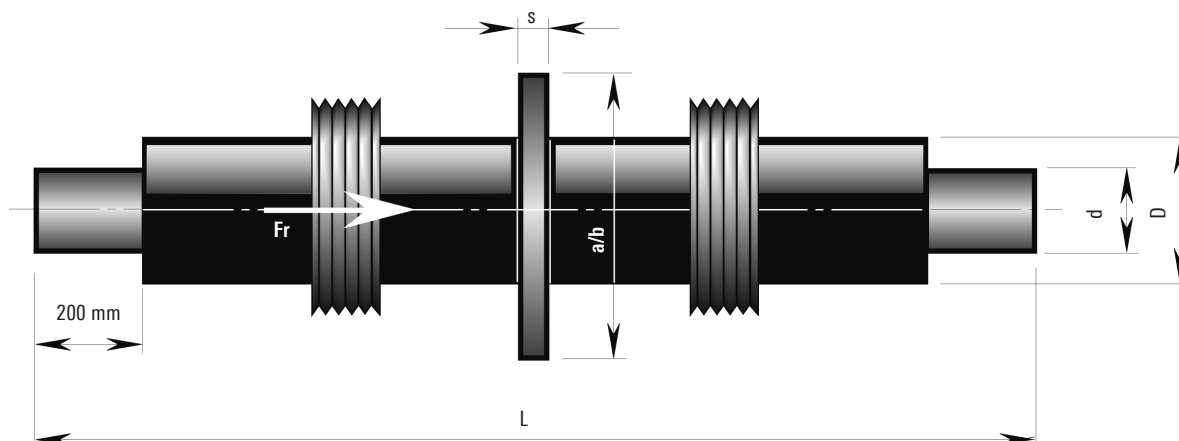

Fr = Friction force

Main pipe					Ancor flanges				
Nominal width	Steel pipe	Insulation thickness 1	Insulation thickness 2	Insulation thickness 3	Nominal length	Insulation thickness 1	Insulation thickness 2	Insulation thickness 3	
DN	d	D	D	D	L	a/b x s	a/b x s	a/b x s	
	mm	mm	mm	mm	mm	mm	mm	mm	
20	26.9	90	110	125	2000	200 x 15	200 x 15	200 x 15	
25	33.7	90	110	125	2000	200 x 15	200 x 15	200 x 15	
32	42.4	110	125	140	2000	200 x 15	200 x 15	200 x 15	
40	48.3	110	125	140	2000	200 x 15	200 x 15	200 x 15	
50	60.3	125	140	160	2000	250 x 20	250 x 20	250 x 20	
65	76.1	140	160	180	2000	250 x 20	250 x 20	250 x 20	
80	88.9	160	180	200	2000	250 x 20	250 x 20	250 x 20	
100	114.3	200	225	250	2000	330 x 25	330 x 25	330 x 25	
125	139.7	225	250	280	2000	330 x 25	330 x 25	330 x 25	
150	168.3	250	280	315	2000	380 x 25	380 x 25	380 x 25	
200	219.1	315	355	400	2000	500 x 25	500 x 25	500 x 25	
250	273.0	400	450	500	2000	600 x 30	600 x 30	600 x 30	
300	323.9	450	500	560	2000	700 x 30	700 x 30	700 x 30	
350	355.6	500	560	630	2000	700 x 30	700 x 30	700 x 30	
400	406.4	560	630	710	2000	800 x 30	800 x 30	800 x 30	
450	457.2	630	710	800	2000	800 x 30	800 x 30	900 x 30	
500	508.0	710	800	900	2000	900 x 30	900 x 30	1000 x 35	
600	610.0	800	900	1000	2000	1000 x 35	1000 x 35	1100 x 40	

For dimensions of the concrete block (foundation dimensions) and concrete quality, see sheet PRE 6.515.

Figures in mm

Wall sealing rings (PRE 6.355) has to be ordered separately. As an option non thermal and electrically separated fixing points are available on request.

# Reduction piece

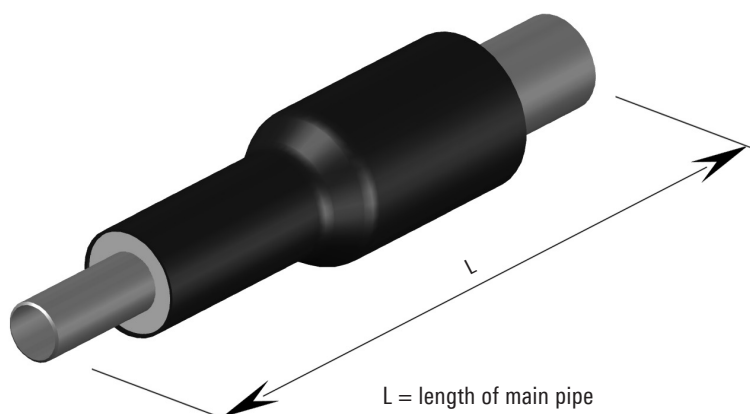

### Description

Reduction pieces are pre-insulated in the factory in the same way as the plastic casing pipe, and they conform to EN448. They are manufactured with a concentric reduction piece to EN 10253 and a welded-on pipe cylinder. For static reasons, pre-insulated reduction pieces are designed to reduce the dimension by a maximum of two steps.

Dimension 1					Dimension 2				Data	
DN 1	d	DS1	DS2	DS3	DN 1	DS1	DS2	DS3	Length	Weight
	mm	mm	mm	mm		mm	mm	mm	mm	kg
25	33.7	90	110	125	20	90	110	125	1500	3.6
32	42.4	110	125	140	20	90	110	125	1500	5.1
					25	90	110	125	1500	5.5
40	48.3	110	125	140	25	90	110	125	1500	5.7
					32	110	125	140	1500	5.8
50	60.3	125	140	160	32	110	125	140	1500	7.8
					40	110	125	140	1500	8.1
65	76.1	140	160	180	40	110	125	140	1500	9.2
					50	125	140	160	1500	10.2
80	88.9	160	180	200	50	125	140	160	1500	11.8
					65	140	160	180	1500	12.8
100	114.3	200	225	250	65	140	160	180	1500	16.3
					80	160	180	200	1500	17.8
125	139.7	225	250	280	80	160	180	200	1500	20.0
					100	200	225	250	1500	22.9
150	168.3	250	280	315	100	200	225	250	1500	27.2
					125	225	250	280	1500	29.2
200	219.1	315	355	400	125	225	250	280	1500	37.8
					150	250	280	315	1500	41.3
250	273.0	400	450	500	150	250	280	315	1500	52.2
					200	315	355	400	1500	59.3
300	323.9	450	500	560	200	315	355	400	1500	71.3
					250	400	450	500	1500	79.7
350	355.6	500	560	630	250	400	450	500	1500	87.0
					300	450	500	560	1500	95.4
400	406.4	560	630	670	300	450	500	560	1500	112.0
					350	500	560	630	1500	117.0
450	457.2	630	670	710	350	500	560	630	1500	130.0
					400	560	630	670	1500	140.0
500	508.0	710	800	900	400	560	630	670	1500	154.0
					450	630	670	710	1500	162.0
600	610.0	800	900	1000	450	630	670	710	1500	190.0
					500	710	800	900	1500	198.0
700	711.0	900	1000	1100	500	710	800	900	1500	296.0
					600	800	900	1000	1500	311.0
800	813.0	1000	1100	1200	600	800	900	1000	1500	349.0
					700	900	1000	1100	1500	374.0

# Vent

## Description

Vents are pre-insulated in the factory in the same way as the plastic casing pipe, and they conform to EN448. The insulation protection on the front of the vent nozzle is provided by a heat-shrunk end cap. The branch is made with a T-piece to EN 10253 and welded-on pipe cylinders, or by extruding the base pipe.

The vent ball valve is manufactured from stainless steel 1.4301, and is supplied complete with plugs. The inner thread corresponds to the nominal width of the vent. All the exposed parts of the valve are made of stainless steel. The nozzle height (h) and the nominal width can be changed at the customer's request.

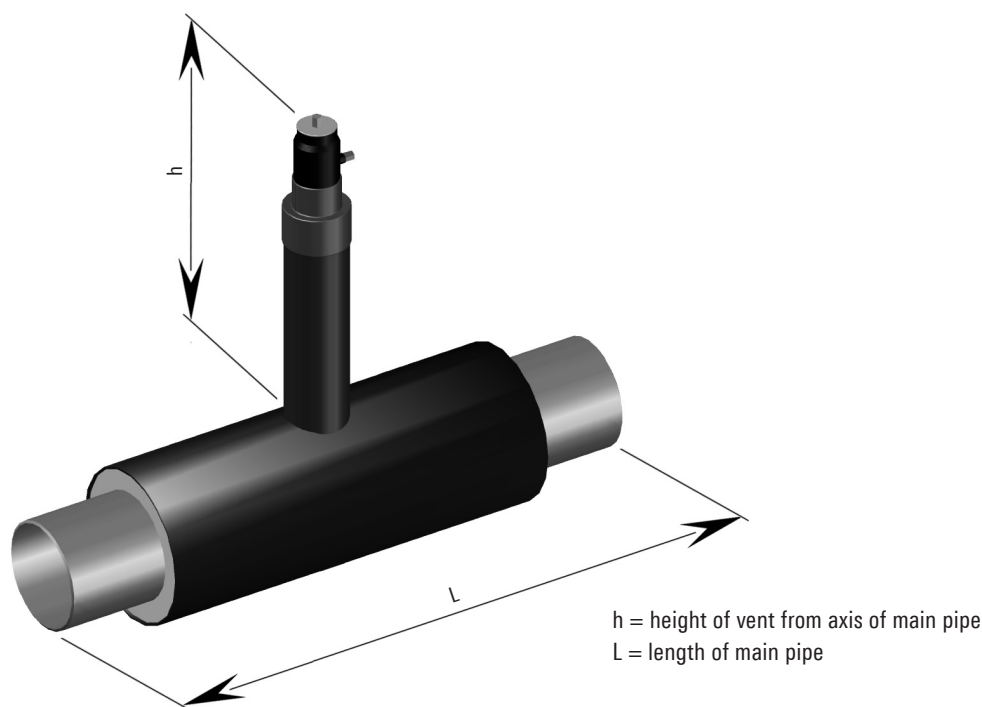

Main pipe						Vent			Weight		
DN	d	DS1	DS2	DS3	L	DN	D	h	DS1	DS2	DS3
	mm	mm	mm	mm	mm		mm	mm	kg	kg	kg
25	33.7	90	110	125	1000	25	90	650	5.3	5.6	5.8
32	42.4	110	125	140	1000	25	90	650	6.6	6.8	7.1
40	48.3	110	125	140	1000	25	90	660	7.1	7.3	7.5
50	60.3	125	140	160	1000	25	90	660	8.2	8.4	8.7
65	76.1	140	160	180	1000	32	110	670	10.6	11.0	11.3
80	88.9	160	180	200	1000	32	110	680	11.9	12.3	12.8
100	114.3	200	225	250	1000	32	110	690	15.6	16.3	17.0
125	139.7	225	250	280	1000	40	110	700	18.9	19.7	20.7
150	168.3	250	280	315	1000	40	110	720	23.5	24.5	25.9
200	219.1	315	355	400	1000	40	110	740	32.6	34.4	36.7
250	273.0	400	450	500	1000	50	125	840	47.5	50.2	53.3
300	323.9	450	500	560	1000	50	125	860	59.8	62.9	67.1
350	355.6	500	560	630	1000	50	125	880	66.5	70.7	76.0
400	406.4	560	630	670	1000	50	125	900	82.9	88.2	91.7
450	457.2	630	670	710	1000	50	125	930	94.4	97.9	101.4
500	508.0	710	800	900	1000	50	125	1000	107.8	116.6	126.0
600	610.0	800	900	1000	1200	50	125	1050	139.6	149.1	159.4
700	711.0	900	1000	1100	1200	50	125	1100	176.9	187.2	198.7
800	813.0	1000	1100	1200	1200	50	125	1150	216.8	228.3	241.3

# Drainer

## Description

The end cap on the vent branch has to be ordered separately. Drainers are pre-insulated in the factory in the same way as the plastic casing pipe, and they conform to EN 448. The branch is made with a T-piece to EN 10253 and welded-on pipe cylinders, or by extruding the base pipe.

The nozzle height (h) and the nominal width can also be produced to the customer's requirements. Flanges, relief valves and ball valves can also be used as closures for the nozzle.

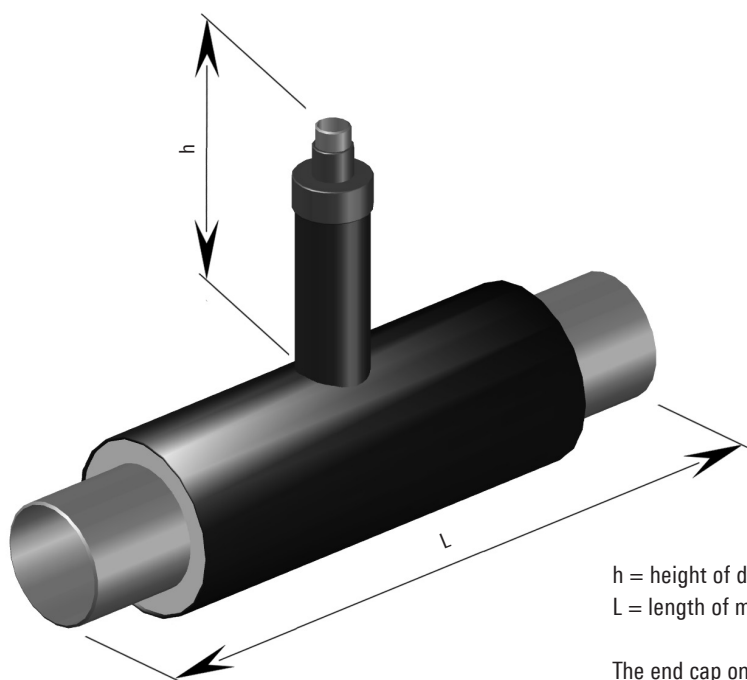

h = height of drainer from axis of main pipe  
L = length of main pipe

The end cap on the vent branch has to be ordered separately.

Main pipe						Drainer			Weight		
DN	d	DS1	DS2	DS3	L	DN	D	h	DS1	DS2	DS3
	mm	mm	mm	mm	mm		mm	mm	kg	kg	kg
25	33.7	90	110	125	1000	25	90	660	6.0	6.6	7.0
32	42.4	110	125	140	1000	25	90	660	6.8	7.4	7.8
40	48.3	110	125	140	1000	25	90	660	8.5	9.1	9.5
50	60.3	125	140	160	1000	32	110	670	10.7	11.2	11.8
65	76.1	140	160	180	1000	32	110	680	12.4	13.0	13.6
80	88.9	160	180	200	1000	40	110	690	14.3	14.9	15.5
100	114.3	200	225	250	1000	40	110	710	17.3	18.1	19.5
125	139.7	225	250	280	1000	50	125	730	21.4	22.6	23.7
150	168.3	250	280	315	1000	50	125	740	24.8	25.8	27.1
200	219.1	315	355	400	1000	80	160	780	36.4	37.9	39.8
250	273.0	400	450	500	1000	80	160	830	47.5	49.8	52.1
300	323.9	450	500	560	1000	80	160	850	59.2	62.1	65.1
350	355.6	500	560	630	1200	100	200	880	81.6	86.4	91.5
400	406.4	560	630	710	1200	100	200	920	100	105	112
450	457.2	630	710	800	1200	100	200	940	112	122	127
500	508.0	710	800	900	1200	100	200	1000	127	135	145
600	610.0	800	900	1000	1200	100	200	1050	163	174	185
700	711.0	900	1000	1100	1200	100	200	1100	208	220	232
800	813.0	1000	1100	1200	1200	100	200	1150	256	268	281

# Fittings installed in the ground

## Description, installation and operating instructions

### General

We only provide systematic heat insulation for ball valves if they are suitable for direct installation in the ground, with or without pre-stressing, i.e.:

- A. if they fulfil the requirements acc. EN 488
- B. if there are no screwed connectors in the insulated area.

### Range of applications

- Up to 160 °C / 16 bar or 140 °C / 25 bar
- Processed, demineralized, clean tap water with low oxygen content
- not suitable for installation in the area of bends and expansion limbs

### Material

- Housing made of steel, forged and welded.
- Ball in stainless steel
- Switching spindle in stainless steel
- Seals in reinforced Teflon
- Ball seal, spring-supported
- Spindle seal, multiple
- Monitoring wire, foamed in
- Heat insulation made of rigid PUR foam
- HDPE casing

### Delivery and storage

- Ball valves in open position
- Protective caps on both pipe ends

### Assembly / installation

- Only weld in the ball valves in the open position, and protect the housing against overheating while doing so
- Install expansion pads in the area of the dome, as per the instructions
- Pay special attention to ensure that the dome has sufficient freedom of movement
- The upper uninsulated section of the spindle must not stand in the groundwater/other water
- The first switching operation must only take place after the pipe has been flushed through (open the gate valve first)
- If there is a risk of frost, uncovered fittings must be completely emptied
- Thoroughly grease the steel parts on the dome
- If there is a provisional pipe end, the free pipe end must be welded shut

### Position indicator

- Milled-in notch on switch spindle square, and pointer

### Activation

- Close by turning to the right (clockwise) as far as the stop (90° for ball valve)

### Operation

- Matching socket wrenches must be used for switching
- Plug-on gears with matching receiver components can be supplied for ball valves (our recommendation for DN 200 and above)
- Do not apply force to the switching shaft
- Do not overtighten the end stops
- Intermediate positions are not allowed for ball valves due to the possibility of wear on the ball seals
- The processed tapwater must not contain any solid particles because they could damage the sealing surfaces

### Maintenance

- Periodically clean the steel parts on the dome and grease them thoroughly
- Switch between OPEN and CLOSED several times, at least every 3 months, until smooth running is achieved
- Check the freedom of movement of the dome
- Check the groundwater level and condition

### Important

**It is essential to follow the above instructions. We and/or the fittings manufacturer cannot provide any warranty for damage due to incorrect installation, handling and maintenance.**

# Ball valve

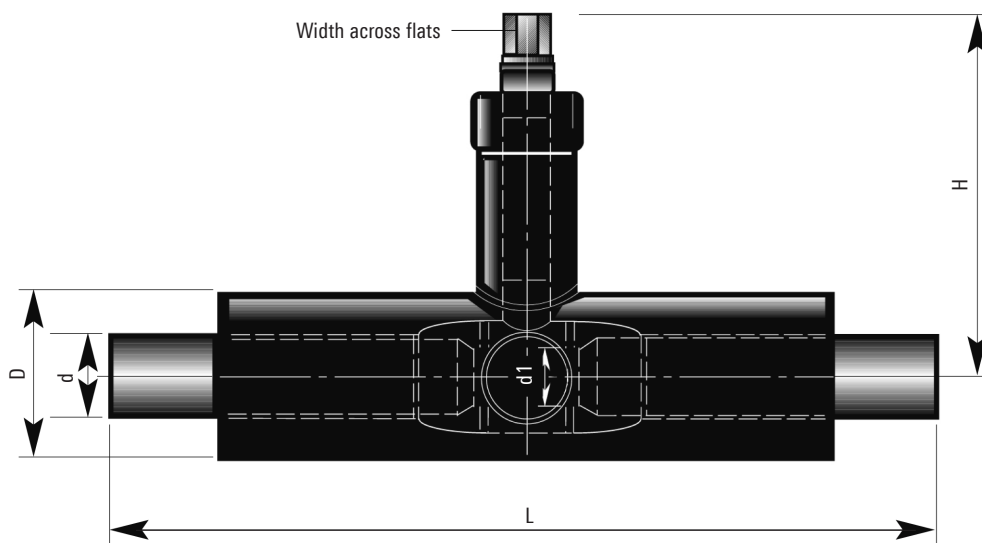

Dimensions depending on type of ball valve

Nominal width DN	Steel pipe d mm	Insulation thickness 1 D mm	Insulation thickness 2 D mm	Insulation thickness 3 D mm	Standard length* L mm	Height H	Wrench size** WS mm
20***	26.9	90	110	125	1500	540	19
25	33.7	90	110	125	1500	540	19
32	42.4	110	125	140	1500	550	19
40	48.3	110	125	140	1500	560	19
50	60.3	125	140	160	1500	560	19
65	76.1	140	160	180	1500	570	19
80	88.9	160	180	200	1500	580	19
100	114.3	200	225	250	1500	580	27
125	139.7	225	250	280	1500	600	27
150	168.3	250	280	315	1500	620	27
200	219.1	315	355	400	1500	580	50
250	273.0	400	450	500	1500	560	50
300	323.9	450	500	560	1800	610	50
350	355.6	500	560	630	1800	610	50
400	406.4	560	630	710	1800	770	50
500	508.0	710	800	900	1800	790	50
600	610.0	800	900	1000	on request		-
700	711.0	900	1000	1100	on request		-
800	813.0	1000	1100	1200	on request		-

Instructions on installation, operation and maintenance as per sheet PRE 6.325

For accessories, see sheet PRE 6.335

\* Length for standard ball valves

\*\* Square socket key see sheet PRE 6.335

\*\*\* Ball valve DN 25 reduced to DN 20

# Ball valve with 2 vents

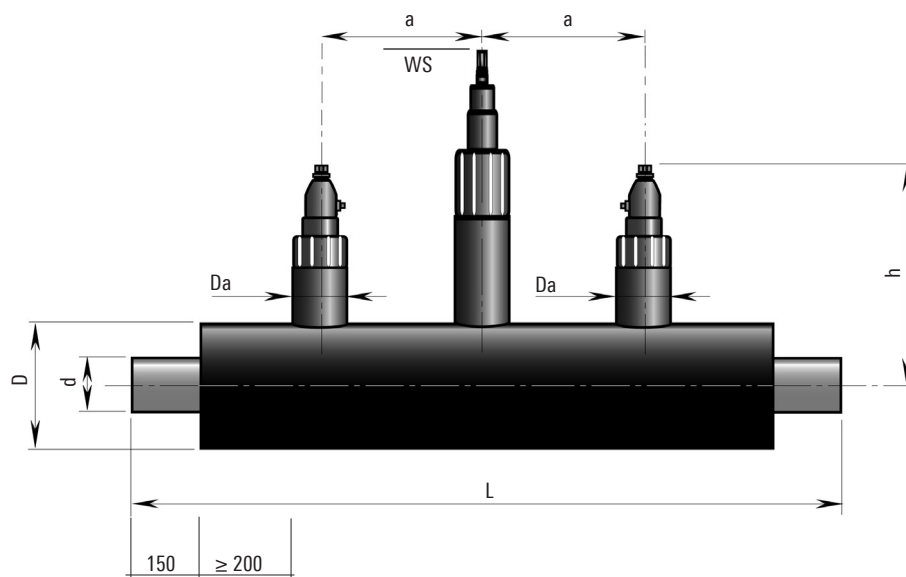

h = high of vent

Main pipe						Wrench size		Draining/venting valve			
Nominal width	Steel pipe	Insulation thickness 1	Insulation thickness 2	Insulation thickness 3	Nominal length	WS	h	Nominal width			
DN	d	D	D	D	L			DN	Da	a	h
	mm	mm	mm	mm	mm	mm	mm	mm	mm	mm	mm
25	33.7	90	110	125	1500	19	540	25	90	320	350
32	42.4	110	125	140	1500	19	550	25	90	320	350
40	48.3	110	125	140	1500	19	560	25	90	320	360
50	60.3	125	140	160	1500	19	560	25	90	320	360
65	76.1	140	160	180	1500	19	570	32	110	320	370
80	88.9	160	180	200	1500	19	580	32	110	320	380
100	114.3	200	225	250	1500	27	580	32	110	320	390
125	139.7	225	250	280	1500	27	600	40	110	320	500
150	168.3	250	280	315	1500	27	620	40	110	320	510
200	219.1	315	355	400	1500	50	580	40	110	320	540
250	273.0	400	450	500	2000	50	610	50	125	400	580
300	323.9	450	500	560	2000	50	660	50	125	500	610

The dimensioning of the venting fitting can be freely selected.

Instructions on installation, operation and maintenance as per sheet PRE 6.325

For accessories, see sheet PRE 6.335

# Ball valve with 1 vents

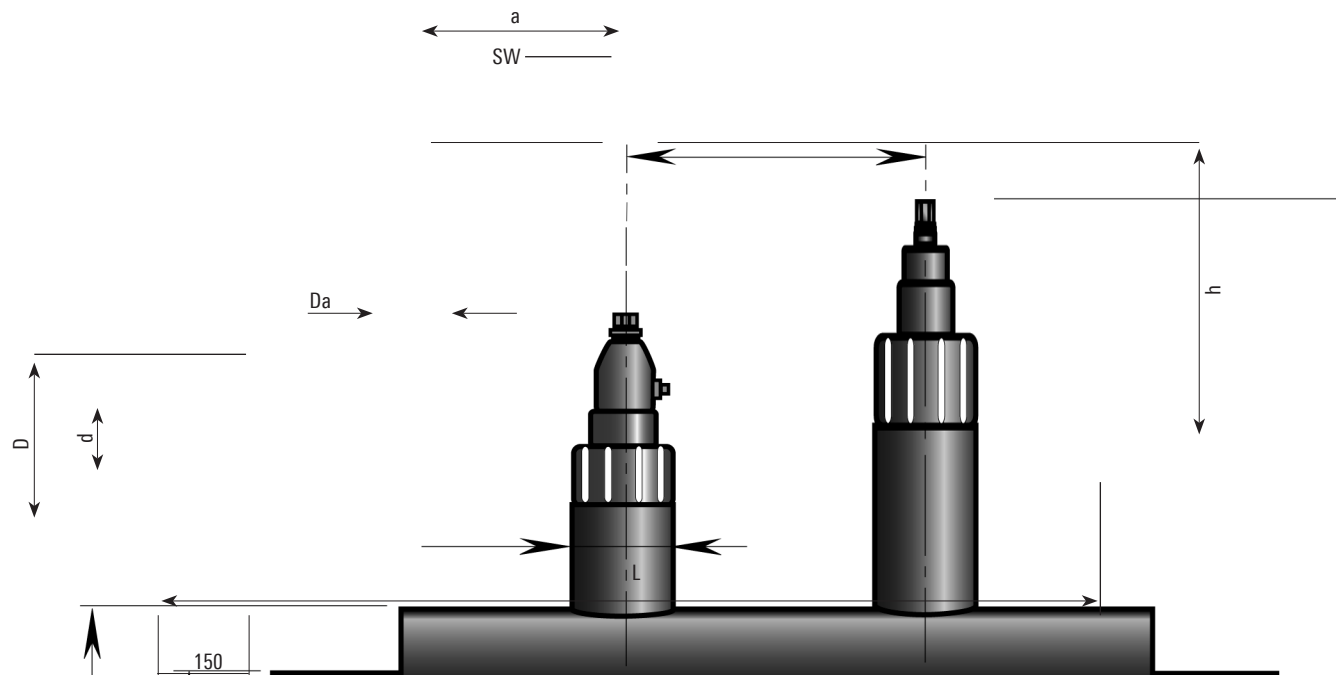

Main pipe						Wrench size		Draining/venting valve			
Nominal width DN	Steel pipe d mm	Insulation thickness 1 D mm	Insulation thickness 2 D mm	Insulation thickness 3 D mm	Nominal length L mm	WS mm	h mm	Nominal width DN mm	Da mm	a mm	h mm
25	33.7	90	110	125	1500	19	540	25	90	320	350
32	42.4	110	125	140	1500	19	550	25	90	320	350
40	48.3	110	125	140	1500	19	560	25	90	320	360
50	60.3	125	140	160	1500	19	560	25	90	320	360
65	76.1	140	160	180	1500	19	570	32	110	320	370
80	88.9	160	180	200	1500	19	580	32	110	320	380
100	114.3	200	225	250	1500	27	580	32	110	320	390
125	139.7	225	250	280	1500	27	600	40	110	320	500
150	168.3	250	280	315	1500	27	620	40	110	320	510
200	219.1	315	355	400	1500	50	580	40	110	320	540
250	273.0	400	450	500	1750	50	610	50	125	400	580
300	323.9	450	500	560	1810	50	660	50	125	500	610

The dimensioning of the venting fitting can be freely selected.

Instructions on installation, operation and maintenance as per sheet PRE 6.325

For accessories, see sheet PRE 6.335



# Ball valve for installation in the ground

Installation diagram

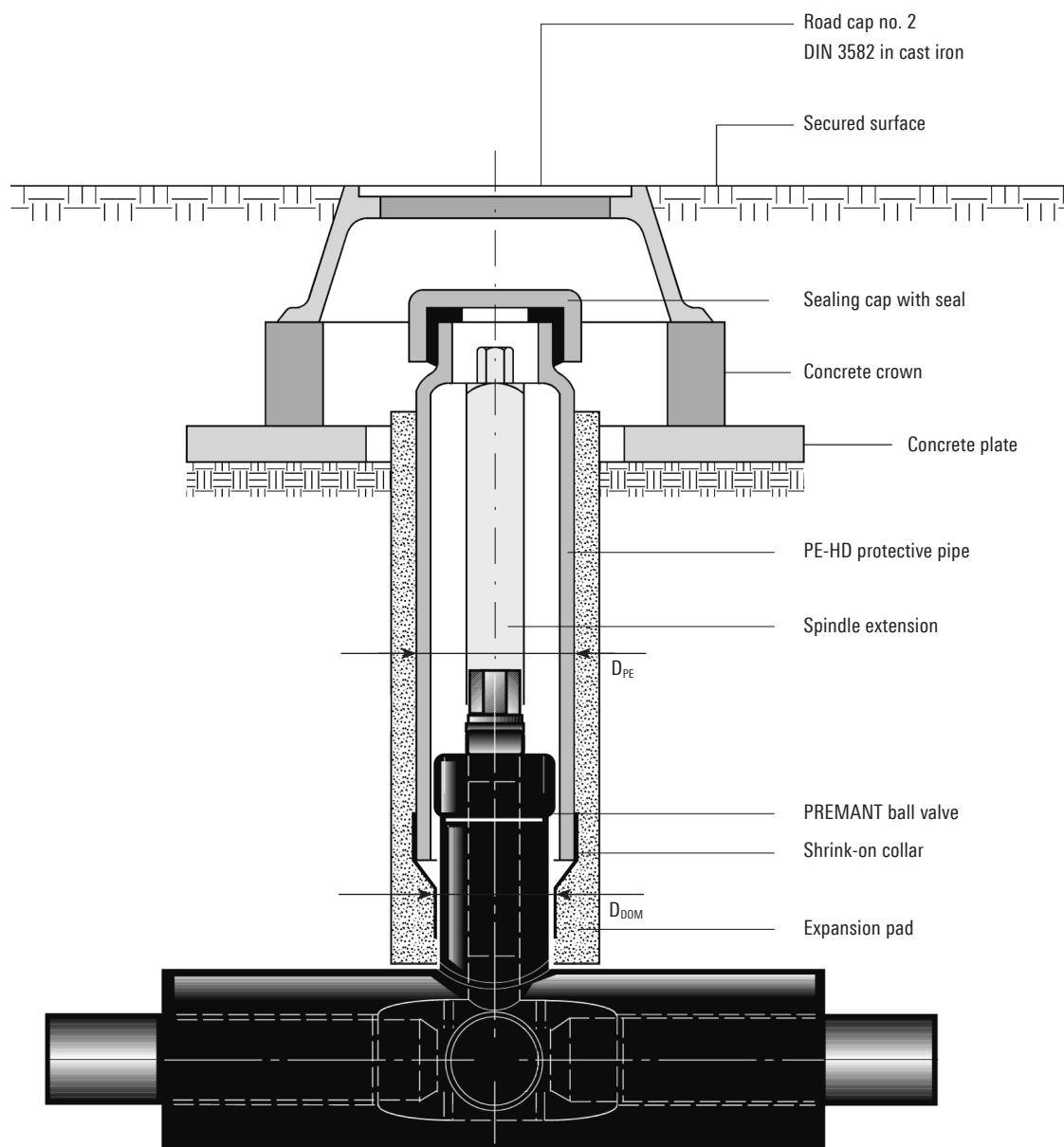

Protective pipes for the spindle must be provided by the customer or others; see sheet PRE 6.520 - 6.525.

## PE protective pipe

Ball valve DN	$D_{DOM}^*$ mm	$D_{PE}^*$ mm
20 ... 80	110	140
100	125	160
125 ... 200	140	180
250	200	225
300	200	225

\* for standard ball valves

Delivery length: 1.0/1.5/2.0 m

Options of supply: – without sealing cap (standard)  
– with sealing cap

# Accessories – shut-off fitting

Ball valve

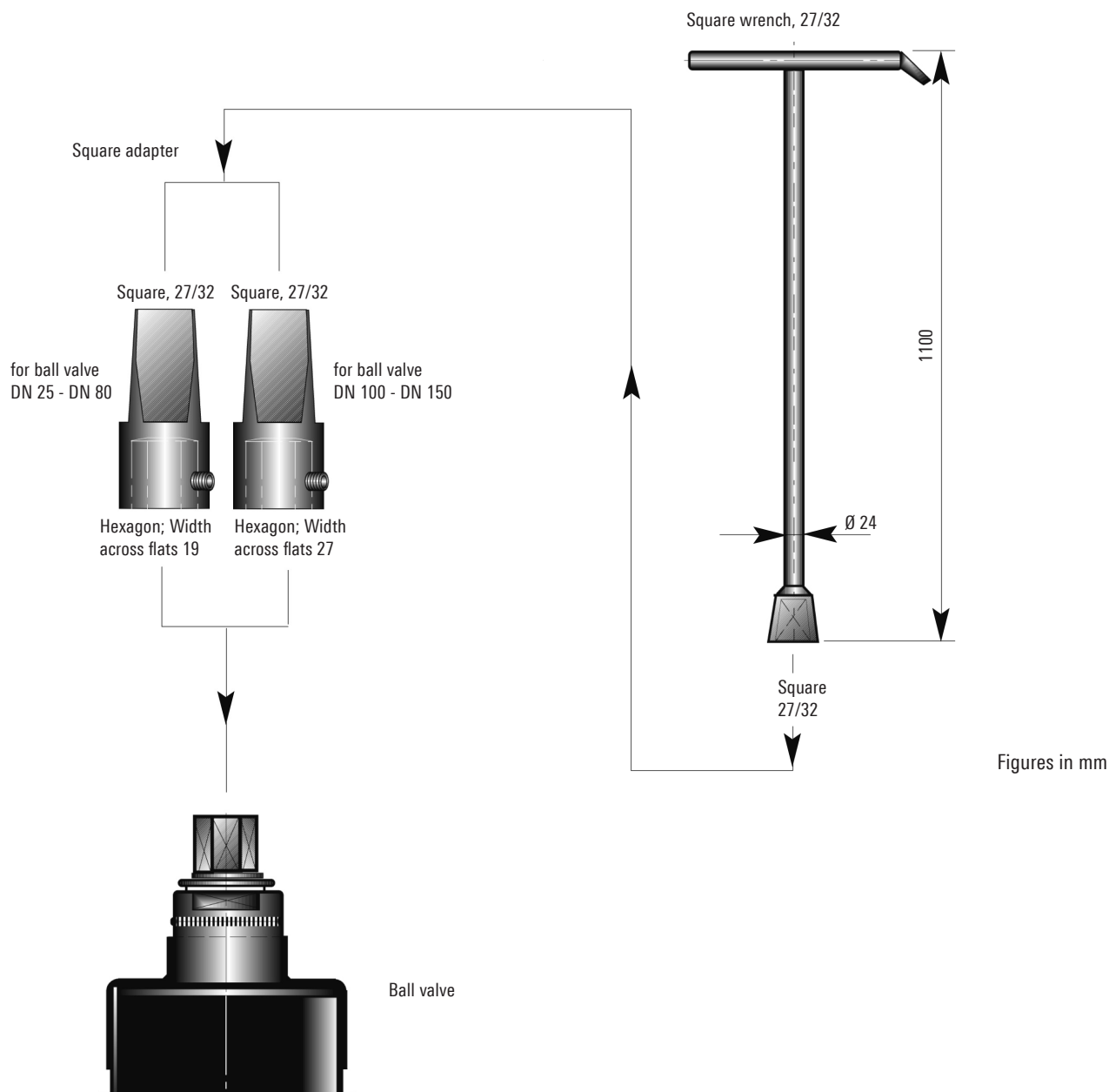

Gear can be supplied on request (for DN 200 or more, a gear is recommended)

# Sleeve joint

Shrink sleeve, non-cross-linked/cross-linked

## 1. PE shrink sleeve, non-cross-linked

The non-cross-linked shrink sleeve consists of a heat-shrunk PE sleeve pipe and the following accessories:

- Shrink-on collars
- Permanently elastic sealing strip, butyl rubber
- Venting plug
- Welded-in PE plug

The shrink sleeves are pushed onto the casing pipe when the pipe is being laid, before the medium pipe weld seams are made. The connection points are then fitted with additional insulation by trained fitting staff who have been tested as per AGFW Worksheet FW 603.

This produces a watertight, non-positive connection between the casing pipe and the sleeve. The sealing strip and the shrink-on collars are used to double-seal the sleeve joint. Technical requirements as per EN 489, AGFW Worksheet FW401, parts 6, 14, 16 and 17.

<b>Nominal width:</b>	90 ... 1200
<b>Length:</b>	700, 1000, 1400 mm

## 2. Shrink sleeve made of cross-linked PE

The cross-linked shrink sleeve consists of molecular cross-linked polyethylene, so only limited welding is possible. The very high shrinkage capacity of this material combined with the sealing strip inserted between the casing pipe and the sleeve produce a very strong non-positive connection.

Because this type of sleeve can withstand high mechanical loads, it is especially suitable for plastic casing pipe sections that are subject to higher stresses (e.g. frequent load alternation, pipes laid in the groundwater zone).

<b>Nominal width:</b>	90 ... 1200
<b>Length:</b>	700 mm

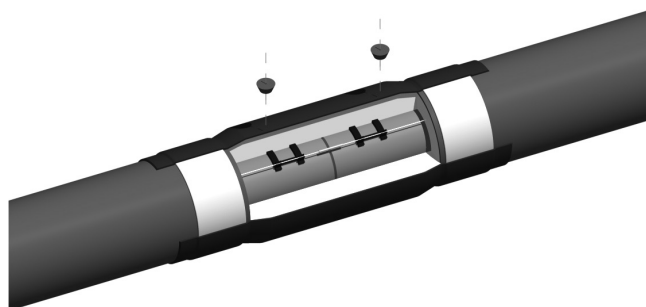
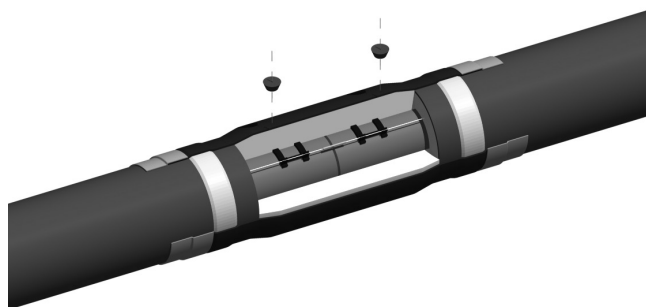

# Sleeve joint

Reduction sleeves, fitting sleeves and shrink-on end sleeves

### 3. Shrink-on reduction sleeves

For reasons related to statics, shrink-on reduction sleeves to insulate steel reduction joints that are welded in by the pipelayer (provided by the customer or others) are designed to reduce the dimension by a maximum of three steps. Their structure corresponds to that of the non-cross-linked PE shrink sleeve, and they must be pushed onto the outer casing before the medium pipe is welded.

The non-cross-linked reduction shrink sleeve consists of a heat-shrunk PE sleeve pipe and the following accessories:

- Shrink-on collars
- Permanently elastic sealing strip, butyl rubber
- Venting plug
- Welded-in PE plug

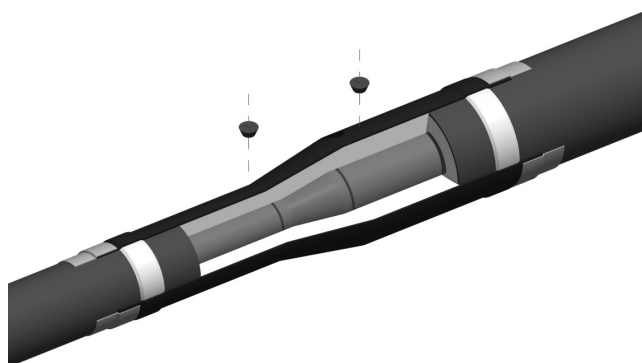

Nom. width	Reduction sleeve			Length
D	D	D	D	L
mm	mm	mm	mm	mm
110	90			700
125	110	90		700
140	125	110	90	700
160	140	125	110	700
180	160	140	125	700
200	180	160	140	900
225	200	180	160	900
250	225	200	180	900
280	250	225	200	900
315	280	250	225	900
355	315	280	250	900

Nom. width	Reduction sleeve			Length
D	D	D	D	L
mm	mm	mm	mm	mm
400	355	315	280	900
450	400	355	315	900
500	450	400	355	1200
560	500	450	400	1200
630	560	500	450	1200
670	630	560	500	1200
710	670	630	560	1200
800	710	670	630	1400
900	800	710	670	1400
1000	900	800	710	1400
1100	1000	900	800	1400

### 4. Fitting sleeve

Fitting sleeves made of non-cross-linked PE are used when it is not possible to push the joint sleeves on due to shortage of space. The fitting sleeve is separated in the axial direction and it can then be moved into position over the points where the pipes are connected. This separation point is welded to guarantee the tightness of the sleeve.

<b>Nominal width:</b>	90 ... 1200
<b>Length:</b>	700, 1000, 1400 mm

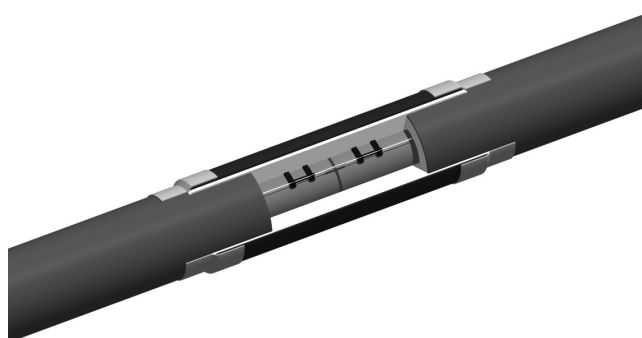

### 5. Shrink-on end sleeve

The shrink-on end sleeve is used to insulate pipe closures in the ground and in buildings or shafts. It has the same structure as a non-cross-linked PE shrink-on sleeve but is sealed on one side with a PE end cover.

<b>Nominal width:</b>	90 ... 1200
<b>Length if end is:</b>	
<b>dished end:</b>	700 mm
<b>one time ball valve:</b>	1400 mm

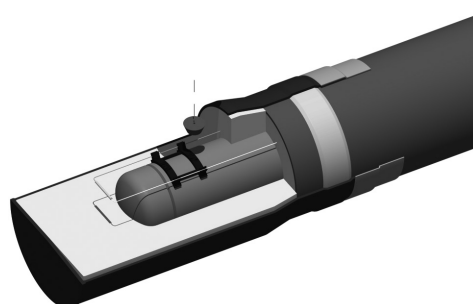

# Brugg VISUCON

Brugg VISUCON is a connection technology which is fundamentally different from the processing of other sleeve systems. VISUCON makes possible visual inspection of the polyurethane foam. This means it is not necessary to destroy the sleeve or the foam.

With the VISUCON connection sleeve, the annular space for the external foaming process is not limited by a polyethylene sleeve, but by reusable forming shells. With this technology, the external sealing connection is not made until after the foaming process is complete. The result and quality of the polyurethane foam can be reliably tested for every sleeve.

Sleeve system parts:

- Polyurethane foam, made of liquid components polyol and isocyanate (cf. PRE 6.410)
- Sealing shrink film
- Sealing tape
- VISUCON sleeve bodies made of integrated shrinkable HDPE

A cylindrical VISUCON shell is used for installation, which is then removed after the polyurethane foam hardens. The two sealing systems are then installed. Due to the system design, no foaming holes are necessary, meaning the plug welding process can also be omitted. The VISUCON sleeve body shrinks across its entire length during installation, whereby the sleeve area does not expand. This unchanging pipe diameter can be advantageous during pipe installation in empty tubes or when driving over cable links.

Nominal size	160...710 mm
Length:	780 mm

Brugg VISUCON is only available as a straight connection sleeve. Non-integrated shrink sleeves should be used for reducing sockets and stop ends.

## Polyurethane half shells

The VISUCON connection sleeve can also be used together with the prefabricated polyurethane half shells. In this case, forming VISUCON shells are not necessary. The remaining installation is identical.

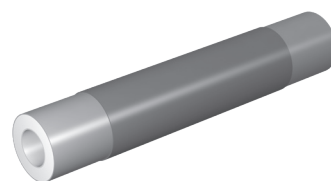
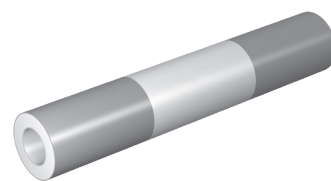
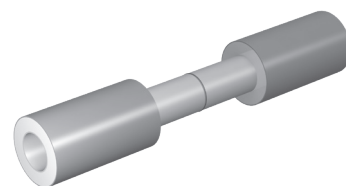

Welding - Foaming - Sealing

# EWELCON electro-welding joint

## System description

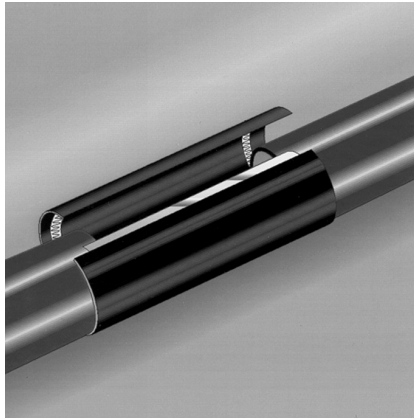
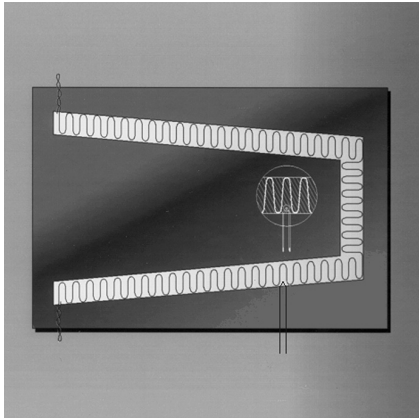

The EWELCON electro-welding joint is the protected name for a welding joint from BRUGG Pipe Systems to produce joints which transmit force, and are watertight and gastight, for plastic pipes - mainly PE-HD casing pipes (pre-insulated plastic casing pipes (KMR)) in the district heating sector.

The EWELCON electro-welding joint is a fully prefabricated HD-PE plate which is only placed ('wrapped') around the two ends of the plastic casing pipe immediately prior to welding. This simplifies the fitting procedure and plays a key part in the high and constant quality of the joint, even in difficult and confined installation locations. The weld seam area can easily be cleaned and dried.

These properties make the EWELCON system especially suitable for repairs and refurbishments on existing pipes.

The 'inside' of the PE-HD plate in the EWELCON electro-welding joint is fitted with a thermal conductor and a temperature sensor. The thermal conductor, a meanderform copper wire, forms a heating spiral with a width of approx. 27 mm. The position of the heating spiral is selected so that when the plate is placed around it, it completely surrounds the interior of the joint. During the welding process, the pipe and plate materials are plastified along the heating spiral, and are homogeneously mixed due to the high expansive pressure of the melts. After the melts cool down, the interior is sealed by a weld seam with a width of approx. 30 mm.

Together with the contact pressure for the weld surfaces, the weld bath temperature is the most important requirement for plastic weld seams of high quality.

This fact is consistently implemented in the EWELCON system.

The required contact pressure is reliably applied by the clamping tool specially developed for this purpose.

The welding process is regulated by a microprocessor-controlled welding appliance. The temperatures of the weld bath and the thermal conductor are monitored and stored throughout the entire welding process. This method ensures that the weld bath temperature is largely independent of disruptive external influences (such as the weather) and thus comparable from one welding operation to the next.

Every joint produced is subjected to a thorough visual inspection and a tightness test, after which it is foamed and the filling and venting bores are sealed with weld plugs.

# EWELCON electro-welding joint

## Technical data

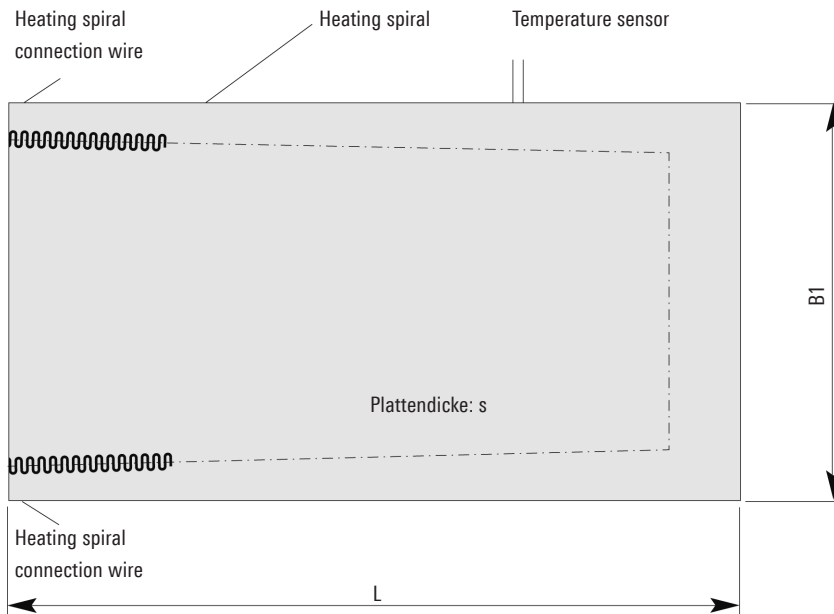

Casing pipe Ø D mm	Width B1 mm	Length L mm	Thickness s mm	Weight		Packaging unit	
				B 700 kg	B 850 kg	B 700 Piece	B 850 Piece
90	700 or 850	450	4	1.2	1.5	18	18
110	700 or 850	515	4	1.3	1.6	18	18
125	700 or 850	560	4	1.5	1.8	18	18
140	700 or 850	610	4	1.7	2.1	16	16
160	700 or 850	675	4	1.9	2.3	16	16
180	700 or 850	740	4	2.1	2.6	16	16
200a	700 or 850	805	4	2.3	2.8	15	15
225	700 or 850	885	4	2.4	2.9	15	15
250	700 or 850	950	4	2.5	3.0	20/40/80	20/40/80
280	700 or 850	1050	4	2.7	3.2	20/40/80	20/40/80
315	700 or 850	1160	4	3.0	3.6	20/40/80	20/40/80
355	700 or 850	1290	4	3.3	4.0	20/40/80	20/40/80
400	700 or 850	1440	4	3.7	4.5	20/40/80	20/40/80
450	700 or 850	1600	4	4.2	5.0	20/40/80	20/40/80
500	700 or 850	1830	6	7.0	8.5	20/40	20/40
560	700 or 850	2020	6	7.7	9.5	20/40	20/40
630	700 or 850	2250	6	8.7	10.5	20/40	20/40
710	700 or 850	2580	8	13.2	16.0	20	20
800	700 or 850	2870	8	14.7	17.8	20	20
900	700 or 850	3190	8	16.5	20.0	20	20
1000	700 or 850	3510	8	18.0	22.0	10/20	10/20

Material: PE80 - DIN EN 32 162 (PE-HD)

Further dimensions on request.

Sleeves up to Ø 225 are pre-rolled for delivery

Sleeve widths: Standard width: B = 700; repair width: B = 850

# EWELCON-S

## System description

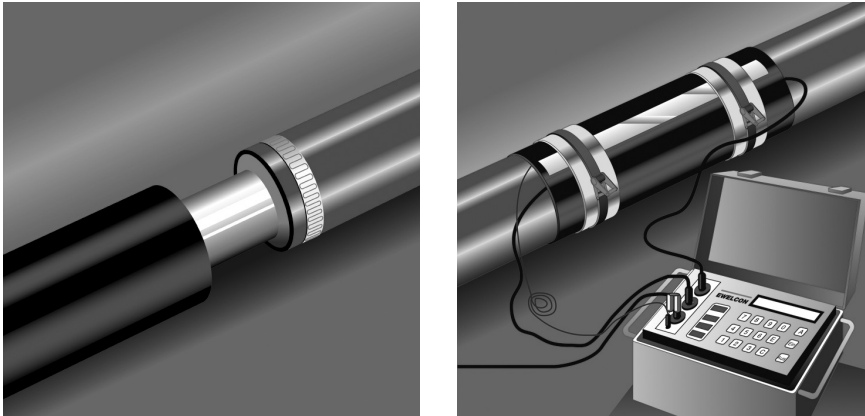

The EWELCON-S Electro-Welding Joint is a member of the "EWELCON family". It is the ideal match for our tried-and-tested EWELCON welding joint for the smaller dimension range.

The shrink-on sleeve and the prefabricated heating elements for the EWELCON-S electro-welding joint are delivered in separate packaging units. The shrink-on sleeve, which is fitted with solar protection foil, is pushed onto the casing pipe before welding the inner pipes. The heating elements are delivered in handy packaging units which are protected against contamination as appropriate for use on construction sites. The heating elements are only placed around the two ends of the plastic casing pipe immediately before welding. The weld seam area can easily be cleaned and dried. This plays a key part in the high and constant quality of the joint, even in difficult and confined installation locations. These properties make the EWELCON-S system particularly suitable for new installations. Repairs and refurbishments on existing pipes are carried out with the EWELCON welding joint using the wraparound method. For quality reasons, the installation is only carried out by fitters who have acquired the necessary qualifications after thorough training from our training staff.

The shrink-on sleeve in the EWELCON electro-welding joint consists of bimodal PE-HD. This ensures optimal long-term properties. The thermal conductor, a meanderform copper wire, is embedded in a PE-HD carrier strip. Each heating element set is fitted with a temperature sensor. The heating elements are fixed onto the prepared casing pipe ends; they adapt to the component tolerances. The special design in the area of the connecting ends ensures constant welding conditions over the entire pipe circumference.

Following the usual on-site method, the shrink sleeve is shrunk down onto the casing pipe ends with a gentle propane gas flame; the heating elements are optimally chambered as this is done. Together with the contact pressure for the weld surfaces, the weld bath temperature is the most important requirement for plastic weld seams of high quality. This fact is consistently implemented in the EWELCON-S system. The required contact pressure is reliably applied by the clamping tool specially developed for this purpose.

The welding process is regulated by a microprocessor-controlled welding appliance. The temperatures of the weld bath and the thermal conductor are monitored and stored throughout the entire welding process. This method ensures that the weld bath temperature is largely independent of disruptive external influences (such as the weather) and thus comparable from one welding operation to the next. The parameters for each welding operation are stored in the welding computer so that they can be read out and documented at a later stage. Furthermore, every joint produced is subjected to a thorough visual inspection and a tightness test, after which it is foamed and the filling and venting bores are sealed with weld plugs.



# EWELCON-S

## Technical data

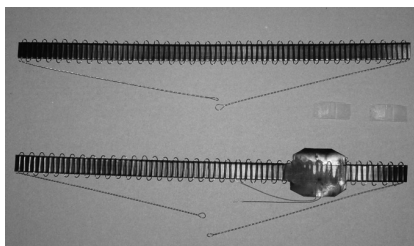

Casing pipe D mm	PE-HD sleeve pipe			Heating element	
	Outer ø mm	Thickness mm	Length mm	Length mm	Width mm
90	107	2.9	700	310	100
110	129	2.9	700	370	100
125	143	3.0	700	420	100
140	156	3.4	700	460	100
160	178	3.5	700	520	100
180	198	3.5	700	580	100
200	224	3.8	700	650	100
225	255	4.3	700	730	100
250	278	4.4	700	810	100
280	306	4.9	700	700	100
315	341	5.5	700	900	100
355	384	5.8	700	-	100
400	430	6.2	700	-	100

EWELCON-S can also be used for reduction sleeves and for shrink sleeves of any desired length.

# Fitting bend



Fitting bends are used as additional insulation for medium pipe bends welded in at the building site by the pipelayer. Fitting bends are made from non-shrinking HDPE pipe. Shrink-on collars are used to seal the pipe on the face side.

The fitting bend comprises:

- Segment bend made from PE sleeve pipe
- Shrink-on collars

Fitting bends are made to measure depending on the bend design (radius, angle, length). The following details are therefore required when placing an order:

- Nominal diameter of the medium pipe
- Nominal diameter of the PE casing
- Bend design or radius
- Angle of the fitting bend

Compliance with the minimum lengths defined in the following table is required if a prefabricated welded bend as per EN 10253/2 is fitted between the adjacent free pipe rod ends.

## Fitting bend, minimum lengths

Angle design:	5.....45°		46.....90°	
	3 D	5 D	3 D	5 D
Da	L	L	L	L
	mm	mm	mm	mm
90				
110				
125	500	500	500	500
125				
140				
160				
180	500	500	500	700
200				
225				
250	500	500	700	700
280				
315				
355	500	700	700	1000
400				
450	500	700	1000	1100

# Wall sealing ring, pipe warning tape

Wall sealing ring

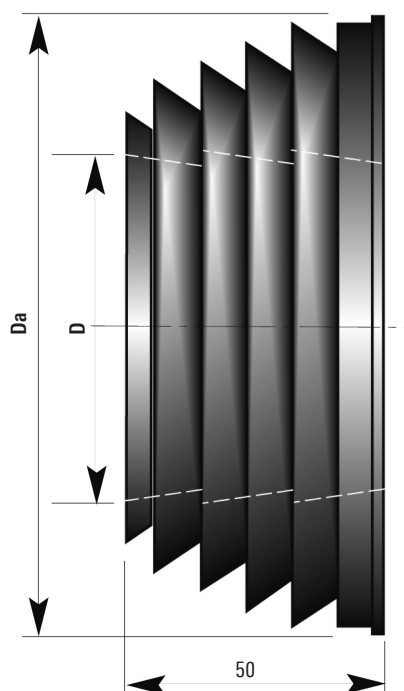

Data table: sealing ring

D	Da
90	133
110	153
125	168
140	183
160	203
180	223
200	240
225	265
250	290
315	355
355	395
400	440
450	490
500	540
560	600
630	670
710	750
800	840

Figures in mm

Pipe warning tape

Width mm	Language	Colour
40	German	blue
100	German/English/French/Italian	blue

Pipe warning tape to be laid in the ground.

Standard roll length, 250 m

Installation depth; see sheet PRE 6.500

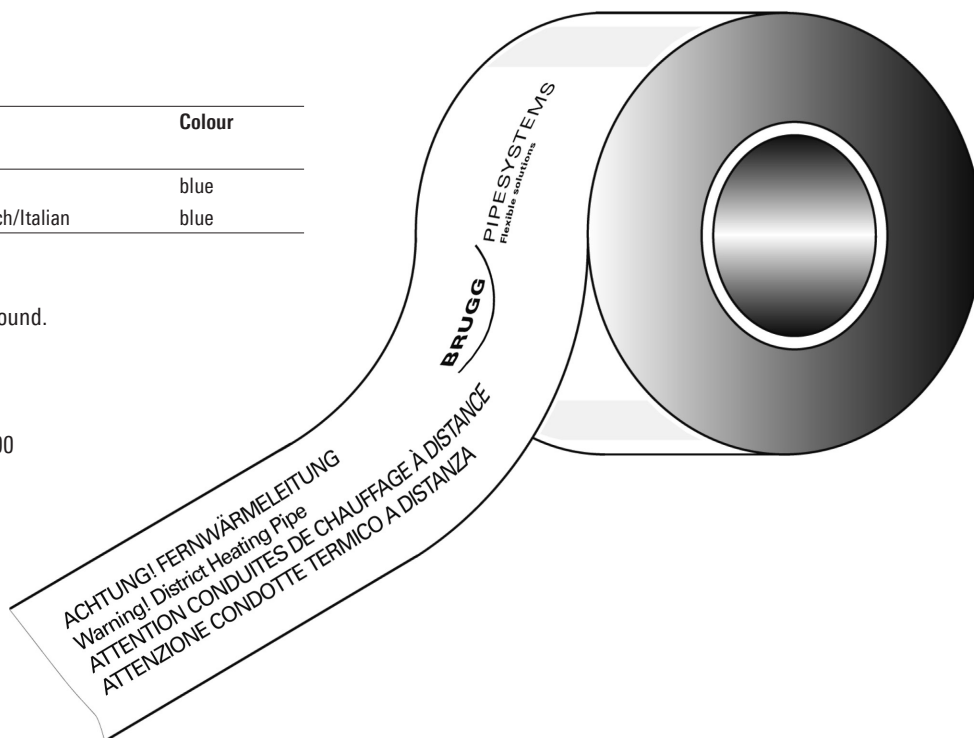

# Shrink-on closure

## Shrink-on closure/end cap

PREMANT shrink-on closures protect the PUR insulation on the front of the PREMANT district heating pipes against splashing water in buildings and shafts. The shrink-on closure is not necessarily watertight in contact with water (flooding). The shrink-on closure also stops gas escaping from the PUR insulation at the end of the pipe.

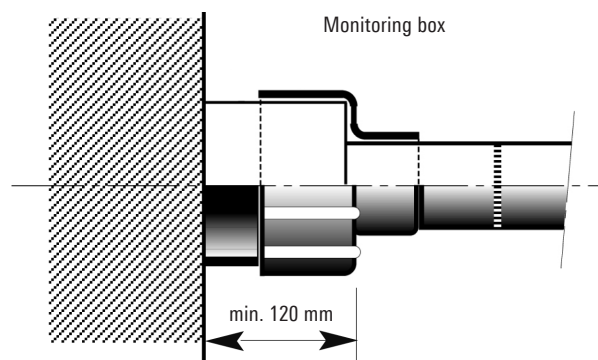

**Material:**  
Heat-shrunk cross-linked polyolefin.  
Coated with sealing adhesive.

**Important fitting note**  
PREMANT shrink-on closures must be pushed onto the end of the PREMANT district heating pipe before welding the inner pipes, and must be protected against the action of heat during welding.

### Allocation of PREMANT dimensions to type of shrink-on closure

Nominal width DN	Insulation thickness 1		Insulation thickness 2		Insulation thickness 3	
	Casing pipe mm	End cap Type	Casing pipe mm	End cap Type	Casing pipe mm	End cap Type
20	90	20	110	20	125	20
25	90	30	110	40	125	50
32	110	40	125	50	140	70
40	110	50	125	50	140	70
50	125	70	140	70	160	80
65	140	70	160	80	180	80
80	160	80	180	80	200	90
100	200	90	225	90	250	100
125	225	100	250	100	280	110
150	250	110	280	110	315	120
200	315	120	355	120	400	130
250	400	130	450	130	500	140
300	450	140	500	140	560	-

# Rigid Foam Beams

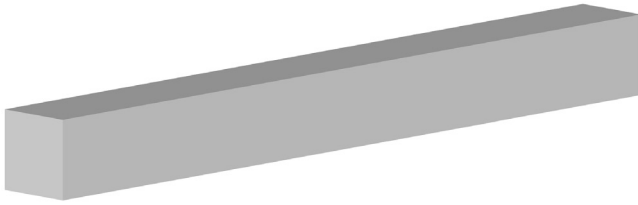

Nominal Size	Size	Length
1	100 x 100 mm	1000 mm

Characteristics	Value	Unit
Material	Polystyrol	
Compressive strength	150	kPa
Density	30	kg/m <sup>3</sup>
Thermal conduction group	040	

Rigid foam beams serve as a support for preinsulated jacket pipes in the pipe trench. PU-rigid foam beams can remain in the sand filled pipe trench.

For large pipelines rigid foam beams are only limited useable. They tend to break under the heavy load if they lay hollow. The additional effort for a plane trench bottom is in most cases not justifiable. German Pipe suggests for pipelines from DN 250 to use sandbags, sand beds or square timbers.

While aligning the pipeline using square timbers it is necessary to remove the square timbers after finishing the welding works and before the sand back-filling. Otherwise the jacket pipe may be damaged due to the thermal expansion.

# Ring seal

Leak-proof sealing against pressurized water for building entries

Wall duct double-seal,  
leak-proof for pressurized water

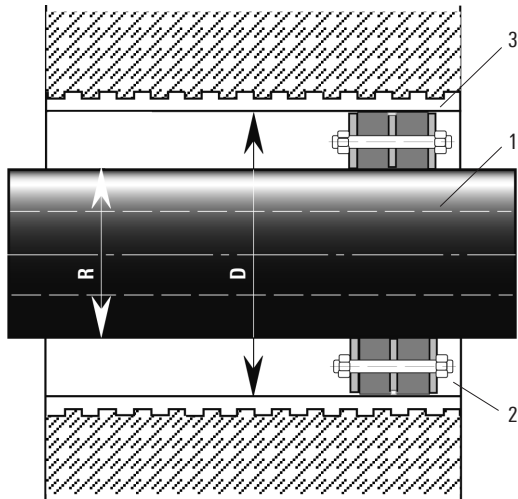

- 1 PREMANT district heating pipe
- 2 Sealing-set, double seal
- 3 Liner pipe made of fibre cement or coated core bore

Wall duct,  
leak-proof for non-pressurized water

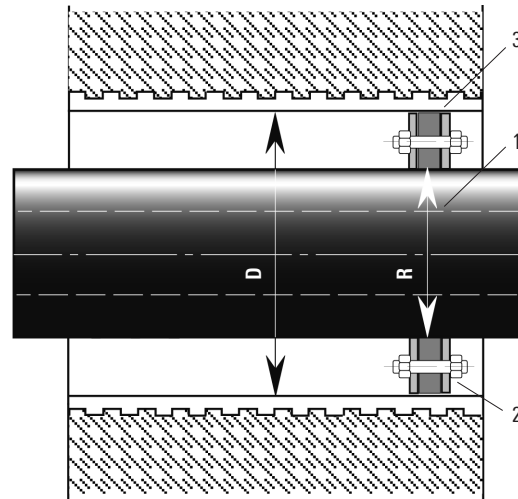

- 1 PREMANT district heating pipe
- 2 Sealing-set, single-seal
- 3 Liner pipe made of fibre cement or coated core bore

Casing pipe diameter	Liner pipe
PE	Core bore
Ø R	Ø D
mm	mm
90	150
110, 125, 140	200
160, 180	250
200, 225	300
250, 280	350
315	400
355	450
400	500
450	600
500	700

## Core bores

Perfect bores are required for installation. As hairline cracks may be present in the concrete or could be caused by processing, it is advisable to seal the entire length of the borehole wall with suitable sealant (such as AQUAGARD).

Tightness can only be guaranteed if this recommendation is followed.

## Installation / trench infill

To avoid deformations at the sealing point, it is especially important during installation and when filling the trench to ensure that no subsequent sinking of the pipe can occur. We also recommend that the pipe is supported or suspended inside the building. Tightness cannot be guaranteed unless these recommendations are followed.

# Expansion pad

## Description

In order to absorb expansion movements of the underground pipe system in bends, branches and reduction pieces, expansion pads must be applied to the outer PE casing in these areas. Expansion pads are manufactured from cross-linked closed-cell polyethylene, are permanently elastic, do not decay and are resistant to chemicals. The expansion zone is designed on the basis of pipe statics calculations.

## Delivery

The delivery scope for an expansion zone of 1 m comprises 2 pieces of expansion pad strip, length 1000 mm, which are glued onto the outer casing at the 3 o'clock and 9 o'clock positions. Laminate is then wrapped around the entire zone in order to prevent sand or soil particles from penetrating between the expansion pad and the PE casing.

**Material:** Polyethylene particle foam

**Nominal width:** Size I 120 mm  
Size II 240 mm  
Size III 360 mm

**Nominal thickness:** 40 mm

Properties	Value	Unit
Apparent (bulk) density	32	Kg/m <sup>3</sup>
Tensile strength	160	kPa
Compressive stress		
50 % deformation at 23 °C	100	kPa
Vibration fatigue test, 80 000 load changes		
- Change in thickness	2,4	%
- Change in hardness number	2,4	%
Absorption of water (volume fraction)		
- after 1d	2,0	%
- after 7d	3,0	%
Thermal conductivity at 10 °C	0,040	W/mK

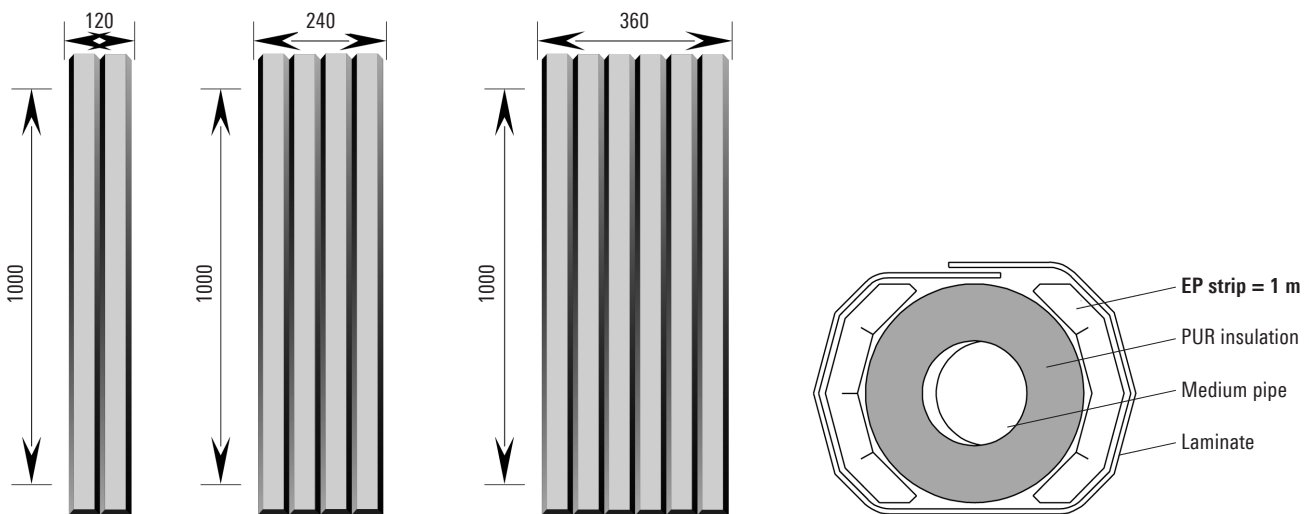

Diameter of outer casing mm	Nominal size		Weight		Volume	
	Name	existing	kg/piece	kg/m	m <sup>3</sup> /piece	m <sup>3</sup> /m
90 up to 160	Size 1	I	0.154	0.307	0.0048	0.0096
180 up to 280	Size 2	II	0.307	0.614	0.0096	0.0192
315 up to 355	Size 3	III	0.461	0.922	0.0144	0.0288
400	Size 4	II+II	0.614	1.229	0.0192	0.0384
500 up to 560	Size 5	II+III	0.768	1.536	0.0240	0.0480
630 up to 670	Size 6	III+III	0.922	1.843	0.0288	0.0576
710	Size 7	III+II+II	1.075	2.150	0.0336	0.0672
800	Size 8	III+III+II	1.229	2.458	0.0384	0.0768
900	Size 9	III+III+III	1.382	2.765	0.0432	0.0864
1000	Size 10	III+III+II+II	1.536	3.072	0.0480	0.0960

# Transport and storage

## Transport

Pipes, preformed parts and accessories are usually delivered by truck 'free site' (as per our valid Conditions of Sale or Delivery). Due to the transfer of risk on delivery, it is advisable for the client to nominate and provide a person responsible for receiving the goods. To avoid costly waiting times, the unloading locations should be suitably prepared.

## Unloading, handling

Unloading is the responsibility of the client/recipient.

Except for pipes up to about DN 80, which can be unloaded manually, lifting gear must be used for unloading. To prevent damage, especially to the thermal insulation, the preformed parts and pipes must not be thrown or rolled.

Figure 1: Suspension gear for accident-proof protective handling

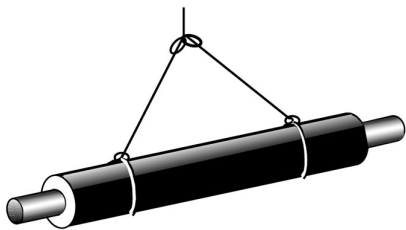

Traverse with textile belts, min. 100 mm wide

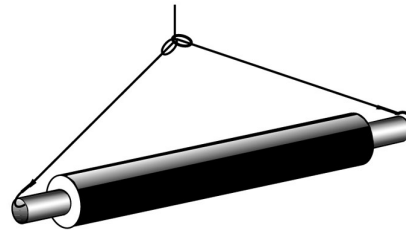

Stay cables at adequate distance from casing pipe.  
Only attach hooks to the steel pipe

Figure 2: Temporary storage on a levelled sand bed

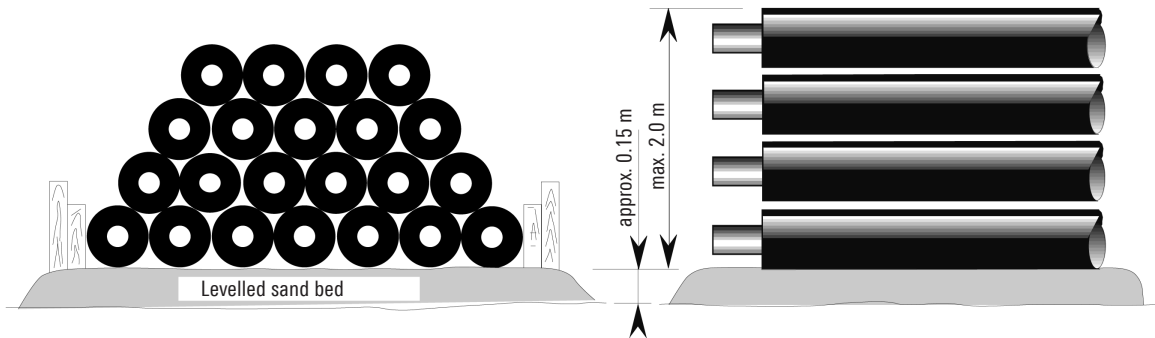
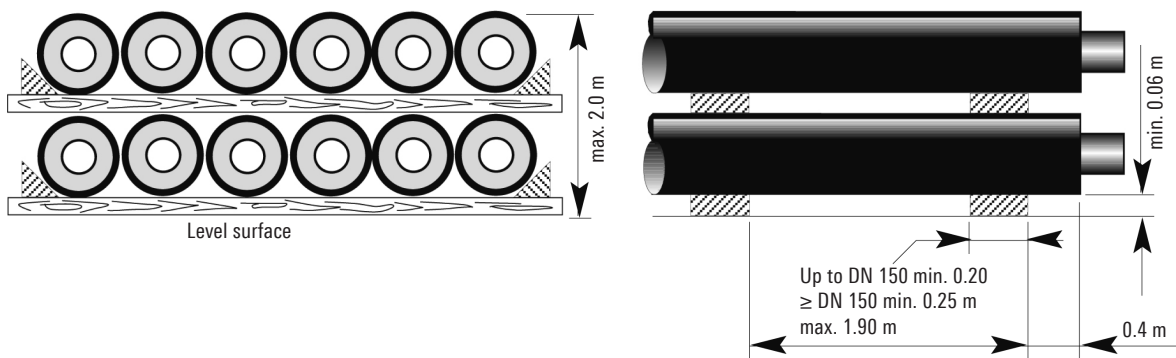

Figure 3: Temporary storage on wooden planks



The pipes and preformed parts have been treated to protect them against moisture in the factory and where possible, they must be stored in a dry, covered location on planks or wooden pallets in order to protect them.



# Storage of preformed parts

Caps at the ends of formed parts protect the medium pipe against external influences. These protective caps should not be removed until the pipe is fitted on site.

Approved formed parts should be stored flat and dry.

Formed parts can also be stored on flat pallets and in mesh boxes in a pyramid formation. The parts should be stacked on top of one another in a manner that ensures stability and an even distribution of weight. Where necessary, stacks on flat pallets should be secured with wedges.

Most importantly, the ends of formed parts should not face upwards. It is imperative to prevent the accumulation of water on the insulation layer (between the medium pipe and casing pipe) to protect the pipe ends against corrosion.

In general, formed parts should be protected from frost and direct sunlight.

They should also be protected from improper handling such as the effects of impact, shock, bending, etc.



# Assembly Foam



Characteristics	Value	Unit
Component A	Polyol	
Colour	ocker	
Density	1.04	kg/m <sup>3</sup>
Solubility in water	yes	
Component B	Isocyanat	
Colour	brown	
Density	1.23	kg/m <sup>3</sup>
Solubility in water	no	

## Storage

The components of the foam system may only be stored and transported in the original canisters. The canisters have to be stored in a dry environment. They should stay airtight closed and sealed. Direct solar radiation and frost have to be avoided.

Are the foam components stored in a closed room, the room has to be ventilated. The minimum ventilation is an air change twice in 24 h. The temperature ought to be between 10 and 25 °C.

While storing together with other substances, these have to be basically compatible. Furthermore we refer to the "VCI-Konzept zur Zusammenlagerung von Chemikalien" of the "Verband der chemischen Industrie".

PUR-foam-components should not be stored for longer than 6 months.

Storage	Value	Unit
Temperature	10 ... 25	°C
Ventilation	twice	each 24 h
Period	< 180	days

## Disposal

Basically a disposal of the fluent components should be avoided. The disposal of this product hat to occur at all times in compliance with the standards of environmental protection and laws of waste disposal as well as the requirements of the local authorities. It is recommended to clarify the details with the responsible waste management company.

Classification				
Substance	ADR/RID-class	Water hazard class	Storage class	Waste class EAK Code
Component A (Polyol)	3	1	Class 3	08 04 09
Component B (Isocyanat)	–	1	Class 10	08 05 01

# Underground construction work, installation

## Pipe installation

- It is essential to ensure that the outer PE casing is not damaged.
- Before welding, the PE sleeve pipes must each be pushed over one side of the pipe ends. Then they must be pulled back over the connection points to protect the insulation.
- The detection wires must always be on top when installing the pipes.
- Make sure that sufficient space is available to apply the supplementary insulation on the sleeves (at least 15 or 20 cm below and between the sleeves).

## Underground work

- The general construction regulations must be observed when excavating the pipe trenches.
- Please ask us for an installation suggestion in case of difficult soil conditions or subsidence, etc.
- The pipe trench must be kept clear of water throughout the installation period.
- PREMANT district heating pipes must be installed on foam pipe supports (sand bags), each at a distance of approx. 1 m from the weld points.
- After installation, the pipe must be filled in on all sides, following the trench profile, with friable, round-edged sand (particle size 0 - 8 mm).
- Fill the pipe to 30 cm below the upper edge of the terrain with excavation material, and compact.
- Install the pipe warning tape, finish filling in the trench and compact.

## Trench profile according to DIN 4124

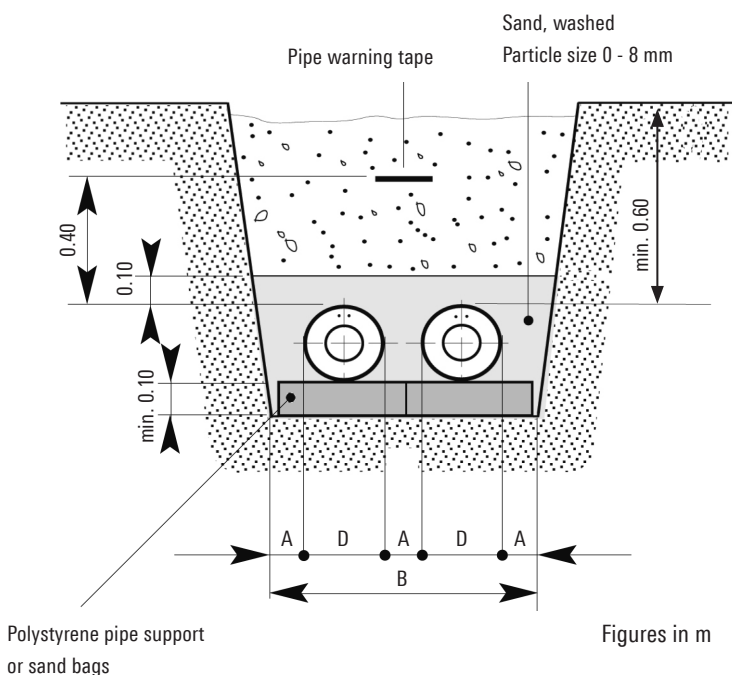

## Trench dimensions

PE outer pipe D mm	Gap A m	Width B m
90	0.23	0.9
110	0.23	0.9
125	0.23	0.9
140	0.28	1.2
160	0.28	1.2
180	0.28	1.2
200	0.28	1.2
225	0.28	1.2
250	0.28	1.4
280	0.28	1.4
315	0.38	1.8
355	0.38	1.8
400	0.38	1.8
450	0.48	2.4
500	0.48	2.4
560	0.48	2.6
630	0.48	2.6
670	0.58	3.1
710	0.58	3.1
800	0.58	3.1

## EWELCON electro-welding joints

- Every joint requires a top hole (sheet PRE 6.501)
- In the pipe zone, clearance of at least 23 cm is required (sheet PRE 6.501)

# Underground construction work, installation

## Trench widening in the area of the expansion pads

The trench must be widened and deepened by at least 0.1 m on both sides in the area of the expansion pads.

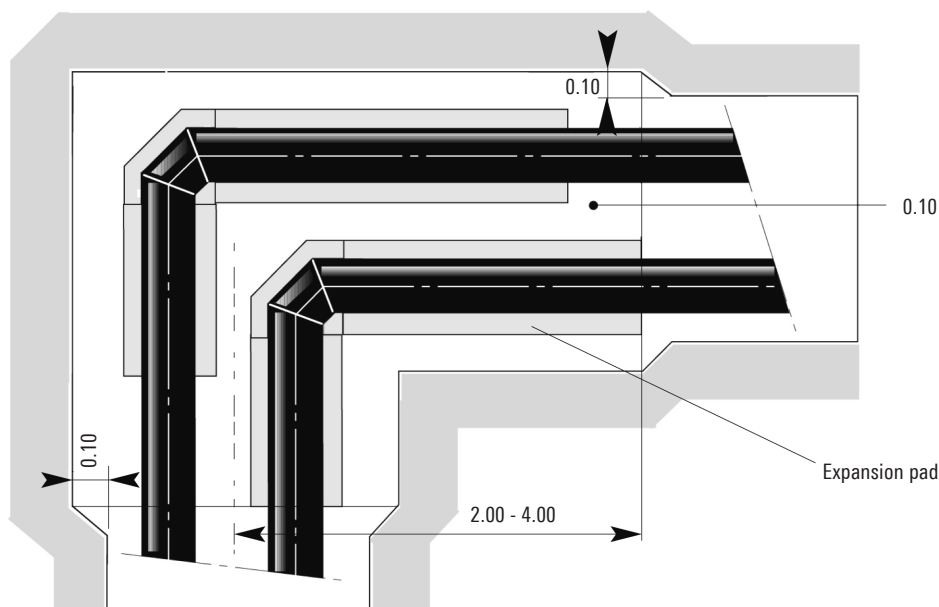

Figures in m

## Trench profile with top hole

To allow the steel pipes to be welded together perfectly, and so that the sleeve joints can be executed neatly, top holes must be made on each weld seam for larger dimensions, but as a minimum on bends and T-branches. This can reduce the width of the normal trench profile.

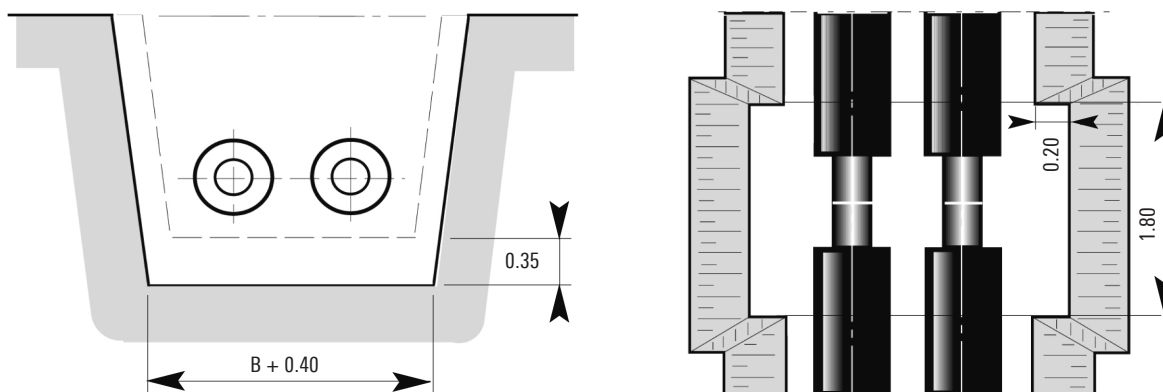

Figures in m

# Filling in the pipe trenches

## Surrounding material (sand)

- Compactable washed sand, max. particle size 8 mm (0 - 8 mm)
- Finest particle component  $\leq 0.25$  mm, not more than 8% if possible
- Friable or smallest possible loam component

As an alternative, so-called cyclone sand/sludge sand, particle size 0 - 1 mm, is permitted (the 'waste' from washed sand). Crushed glass is not permitted as a substitute for sand with PREMANT district heating pipe (it is allowed for FLEXWELL).

## Embedding the pipe in sand (as per Trench Profile sheet)

- Coverage over crown of pipe - at least 10 cm.
- Compaction – very important!
- The sand must be compactly bedded in or compacted by hand, with suitable implements (such as a spade or pick-axe handle) in layers between, below and next to the pipes. No cavities must be created.  
Important: Do not damage the sealing strips and pipes!

## Residual infill of the pipe trench

- The rest of the trench must be filled in with layers of compactable material, such as excavated material and/or fine gravel which must be well compacted. Local regulations govern the use of excavated material and the minimum thickness of the fine gravel layer.
- To compact the material, use a vibrator providing max. 100 kPa pressure/unit of area. Earliest compaction: from 30 cm coverage of pipe crown. Remember: install pipe warning tape and any protective pipes (not over the pipes) (approx. 30 cm above pipe crown).
- Top layer: use humus or HMT according to regulations.

If coverage is insufficient (< 60 cm) and in zones with heavy traffic loads, pressure distribution plates must be installed over the sand layer to relieve pressure on the pipes.

In general, all construction and safety regulations must be followed.

# House lead-in

Wall seal – neoprene rubber

## Wall leadthrough

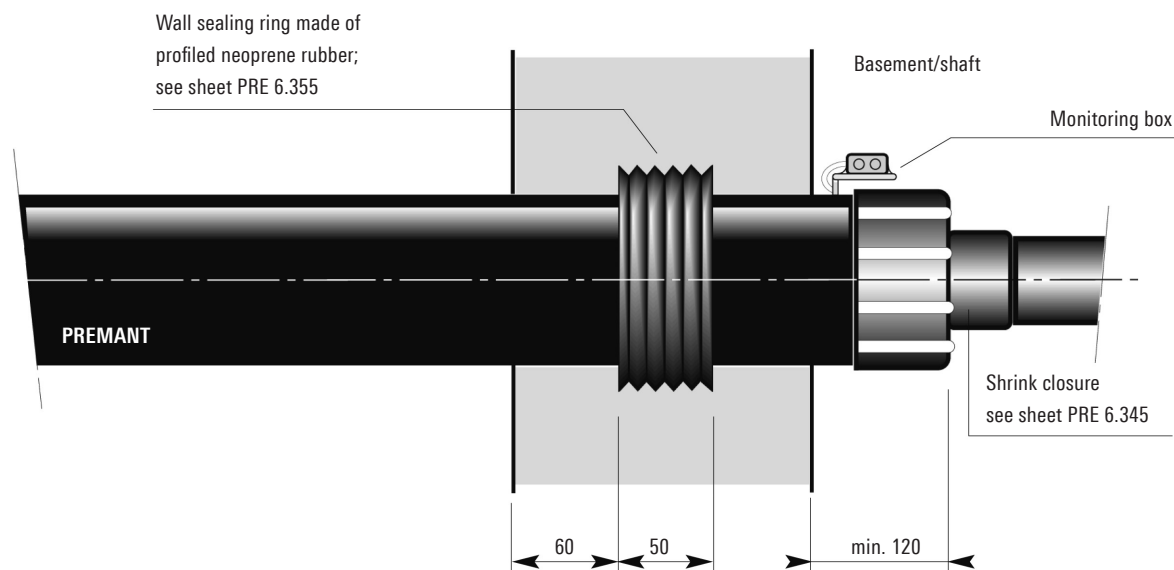

## Wall opening

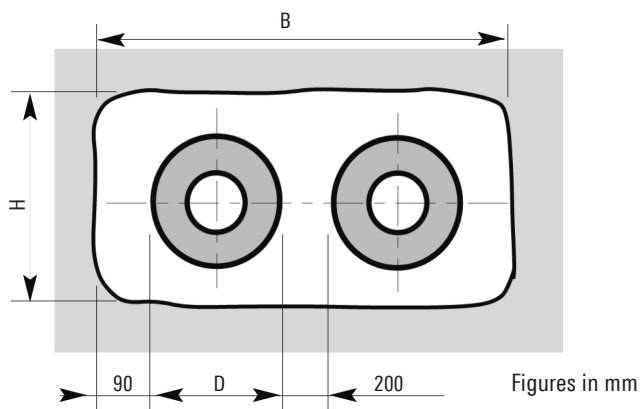

## Wall opening dimensions

D	90	110	125	140	160	180	200	225	250	280	315	355	400	450	500	560	630	710	800
B	540	580	640	640	680	720	760	810	860	920	990	1070	1160	1260	1360	1480	1620	1780	1960
H	250	300	300	350	350	350	350	400	400	450	450	500	550	600	650	750	800	900	990

Figures in mm

# Installation instructions

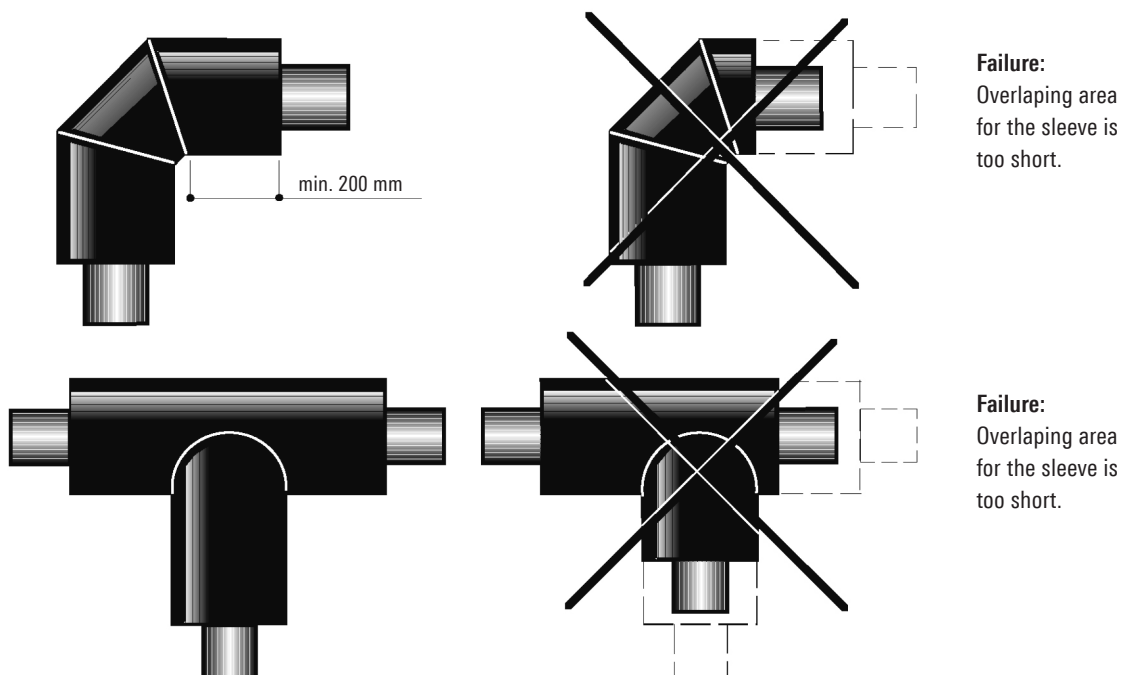
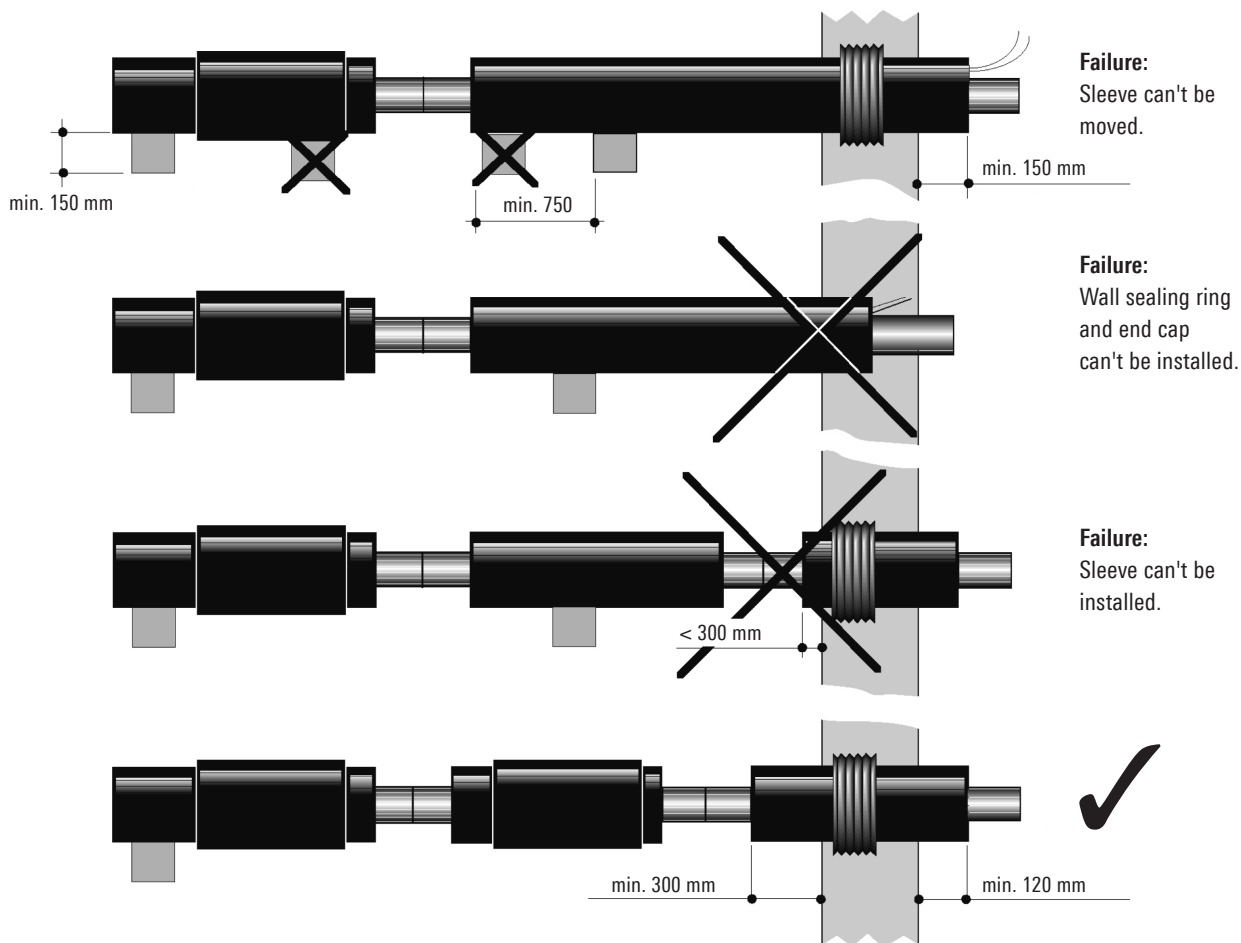

# Concrete block for fixed point

For maximum fixed point forces

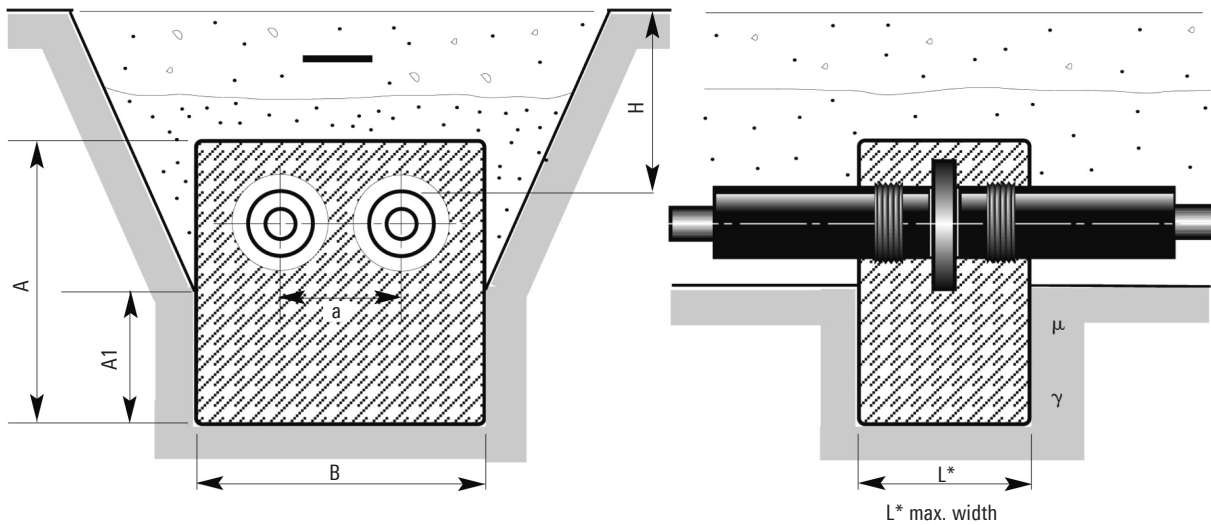

For divergent fixed point forces and soil conditions, the foundation dimensions must be calculated.

Steel pipe		Fixed point force $F_s \text{ max}$ kN	Concrete block dimensions				Pipe distance
DN	d mm		B m	A1 m	A m	L* m	a mm
20	26.9	66.5	0.8	0.40	0.8	0.8	270
25	33.7	83.7	0.8	0.40	0.8	0.8	270
32	42.4	107.2	1.0	0.40	0.8	0.8	280
40	48.3	123.1	1.0	0.45	0.9	0.8	280
50	60.3	172.4	1.2	0.55	1.1	1.0	295
65	76.1	219.9	1.4	0.65	1.2	1.0	320
80	88.9	284.1	1.6	0.80	1.3	1.0	340
100	114.3	412.9	2.0	0.95	1.6	1.0	390
125	139.7	507.6	2.2	1.15	1.7	1.0	415
150	168.3	680.9	2.5	1.40	2.0	1.3	450
200	219.1	1000.6	3.0	1.70	2.4	1.3	550
250	273.0	1388.5	3.5	2.10	2.9	1.3	680
300	323.9	1847.0	4.2	2.25	3.2	1.5	745
350	355.6	2052.0	4.5	2.40	3.3	1.5	810
400	406.4	2592.0	5.2	2.40	3.5	1.8	890
450	457.2	2920.0	5.6	2.60	3.6	2.0	890
500	508.0	3240.0	5.6	2.60	3.8	2.0	980

### Calculation basis for the size of the concrete block

- Max. thrust for 2 pipes:  $F_s \text{ max} = 2 \cdot A_s \cdot \delta T$ , [  $\delta T = 165 \text{ N/mm}^2$ ,  $\Delta T = 70 \text{ °K}$  ]
- Coverage height  $H = 0.8 \text{ m}$
- Foundation dimensions are based on a frictional angle of  $\varphi = 32.5^\circ$  for friable soils (coefficient of friction  $\mu = 0.40$ )
- Apparent density  $\gamma = 18 \text{ kN/m}^3$
- Ground specification acc. DVGW GW 310

### Concrete quality

- P 350 to DIN 1045, impermeable to water with armouring



# Sectional drainage, sectional venting

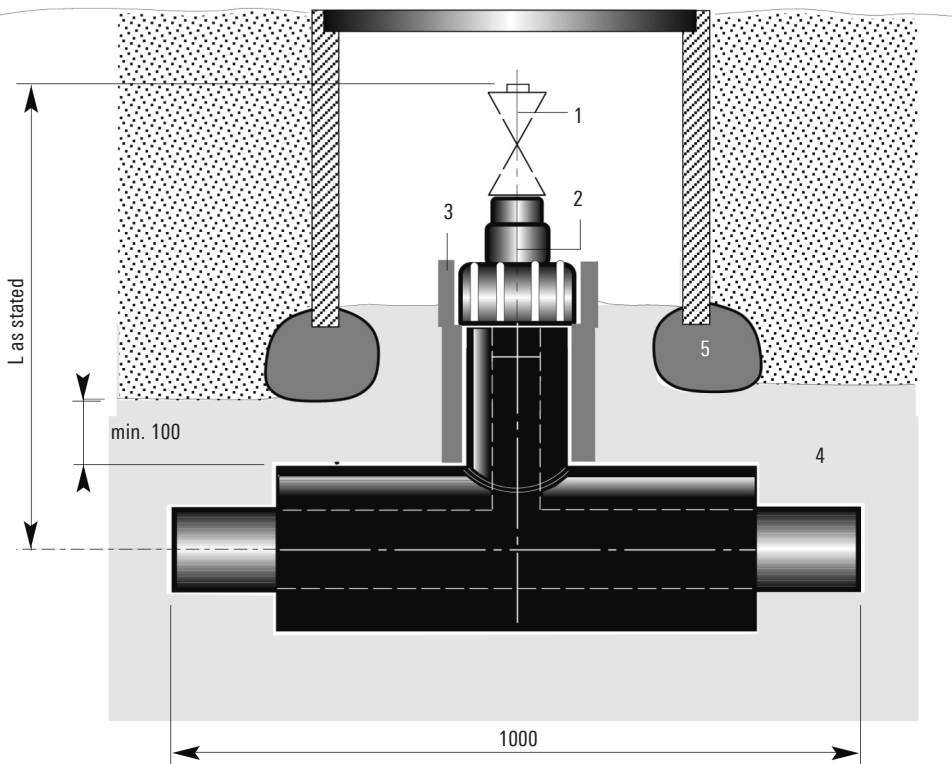
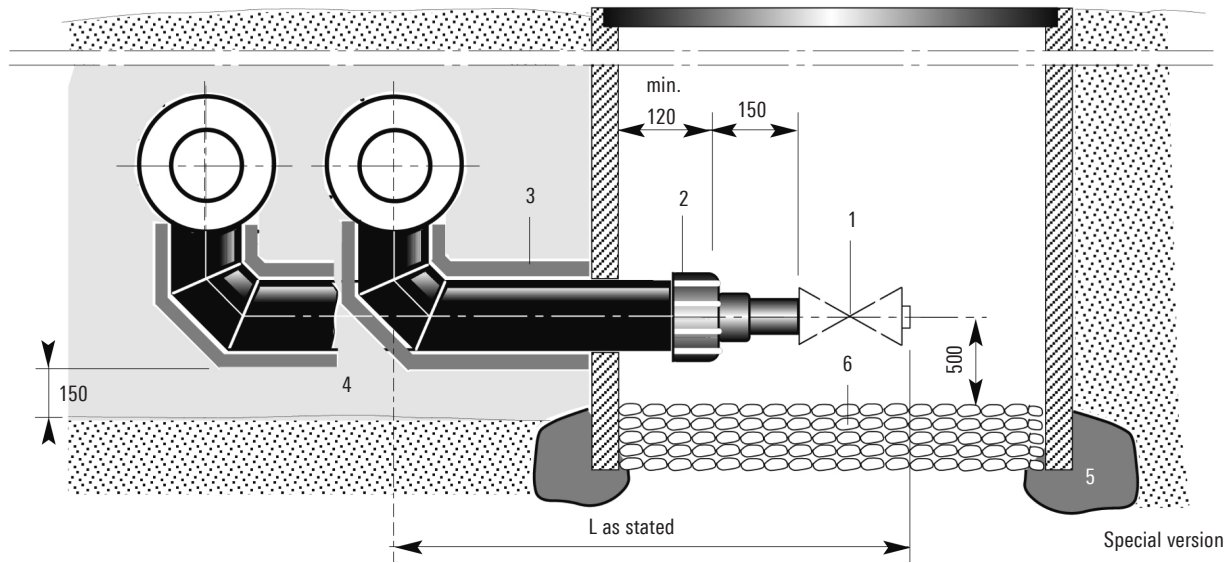

Figures in mm

- 1 Valve, supplied by customer or others
- 2 Shrink-on closure, delivered loose
- 3 Expansion pad
- 4 Sand
- 5 Lean concrete
- 6 Soakaway gravel

# Underground construction for ball valve

Shafts with drive-over cast cover

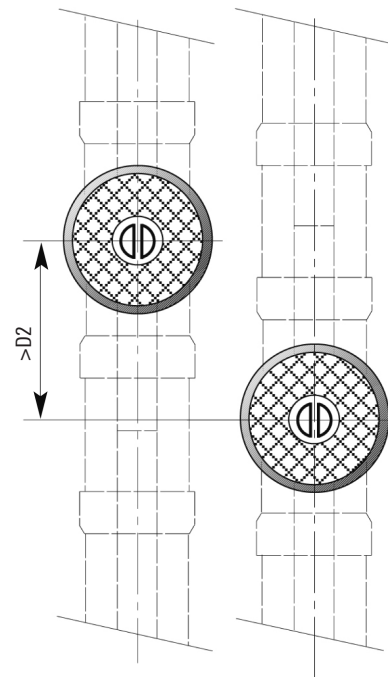
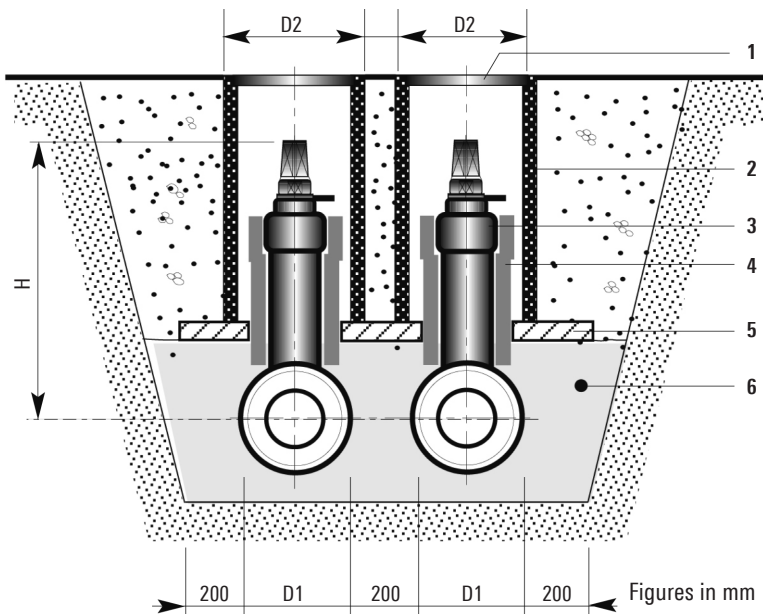

DN	D1 mm	H mm	D2 mm
20	125	470	
25	125	470	
32	140	470	
40	140	490	
50	160	500	250
65	180	510	250
80	200	520	250
100	250	560	
125	280	570	
150	315	590	
200	355	630	300
250	450	670	300

- 1 Cast cover, drive-over (e.g. Von Roll)
- 2 Cement pipe
- 3 Ball valve
- 4 Expansion pad
- 5 Support plate
- 6 Sand filling (particle size 0 - 8 mm)

# Tapping technology

## System description

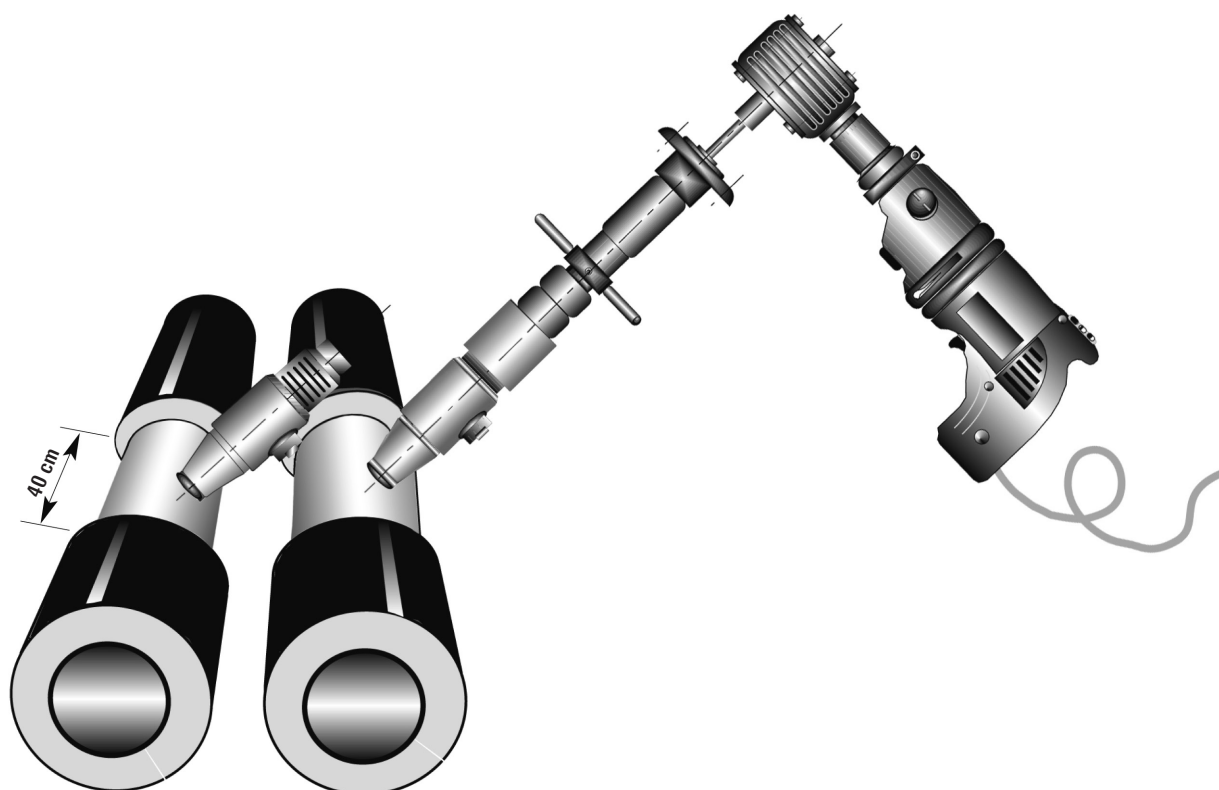

Important: Tapping technology must only be processed by specialist staff.

Tapping systems are designed to produce pipe branches under pressure. Today's equipment and components are the results of a product development process which has combined proven solutions with new findings. This tapping method achieves major cost savings thanks to simple and cost-effective working procedures, and fitting work which can be carried out quickly and reliably without interruptions to operation.

The tapping device for weldable joints on steel pipes and containers can be used for branch dimensions of DN 25 to DN 100, up to 25 bar and 140 °C. On branches, the tapping block is welded to the part to be tapped, either directly or with a weld ring if necessary.

The tapping blocks are designed with a reduced opening. They can be used in district heating pipes and various process pipes.

Tapping pipe branches under pressure has the advantage that they can always be produced in the desired location at a later stage.

Larger dimensions can be executed with another system on request.

# Tapping technology

## Dimensions and measurements

### Fittings with reduced through passage

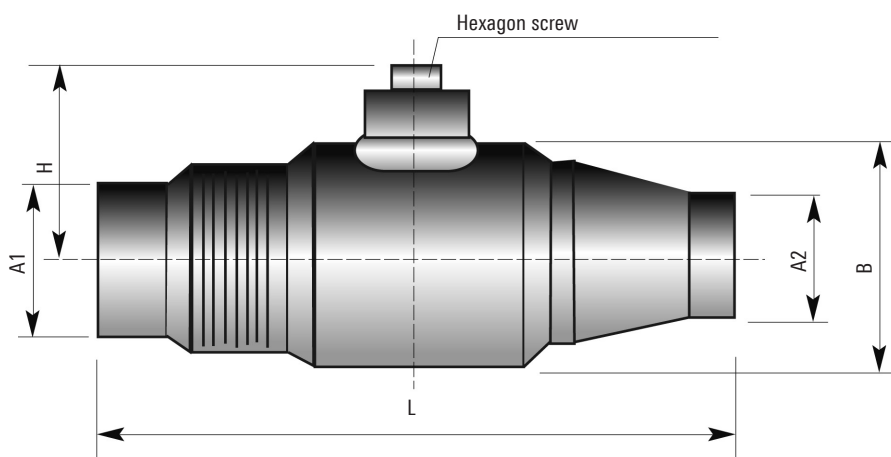

### Tapping ball valve with fully welded housing in St 37 Ball in nickel chromium steel with PTFE seals

Dimension	DN 25*	DN 32	DN 40*	DN 50	DN 65	DN 80	DN 100
Ball opening	25	25	40	40	50	65	80
Bore diameter	24	24	40	40	48	65	79
Flow value (K <sub>vs</sub> ) [m <sup>3</sup> /h]	26	41	68	112	200	380	620
A1 (house connection branch)	33.7 x 2.9	42.4 x 2.9	48.3 x 2.9	60.3 x 3.1	76.1 x 3.1	88.9 x 3.2	114.3 x 3.6
A2 (connecting branch to main pipe)	37.0 x 5.8	37.0 x 5.8	54.0 x 6.7	54.0 x 6.7	63.0 x 7.0	82.0 x 8.0	100.0 x 9.0
B	60.3	60.3	88.9	88.9	114.3	133.0	159.0
H	46.0	46.0	57.0	57.0	70.0	80.0	92.0
L	145.0	145.0	200.0	200.0	260.0	265.0	275.0
Sealing screw, hexagon socket	10	10	10	10	14	14	14
Weight [kg]	1.3	1.2	3.5	3.4	5.1	6.7	11.3
Min. main pipe Ø	DN 32	DN 40	DN 50	DN 65	DN 80	DN 100	DN 125
Min. casing pipe Ø (branch)	110	125	125	140	160	180	225

\* Dimensions with full through passage  
Larger dimensions with different tapping systems on request

Figures in mm

# Tapping technology

Preparation of weld seam and seam structure

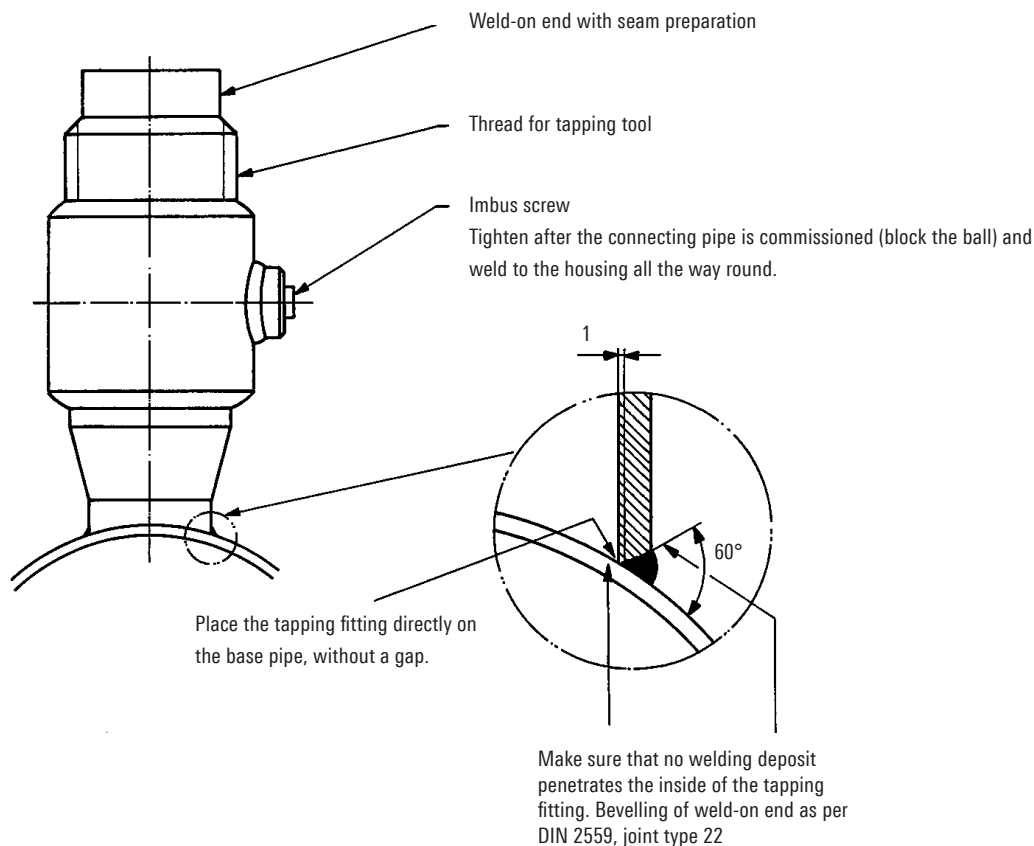

## Weld seam structure:

E-weld (2 - 3 layers) with Kb electrodes, basic (alkaline)  
Type E5155B10 DIN 1913 Ø 2.5 mm

## Important during welding!

- Ball must be exactly in the open position.
- Avoid excessive temperature stress on the Teflon seals by cooling the fitting between the individual weld seam layers (cool the fitting with a wet cloth / waiting time between individual weld seam layers)

# Tapping technology

Junction branch at top with 45° PRE bend

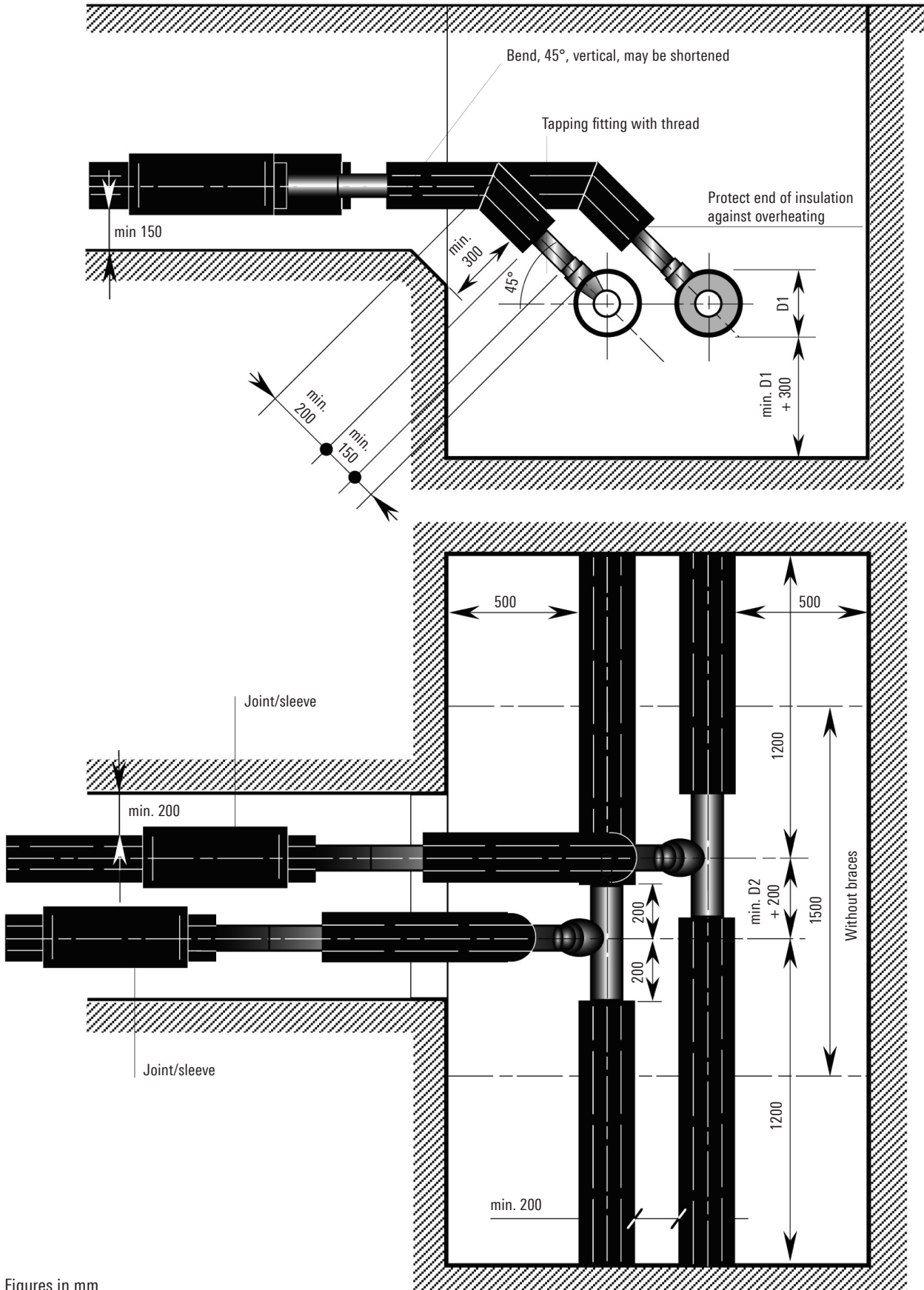

Figures in mm

# Tapping technology

Junction branch at top with 45° welded bend

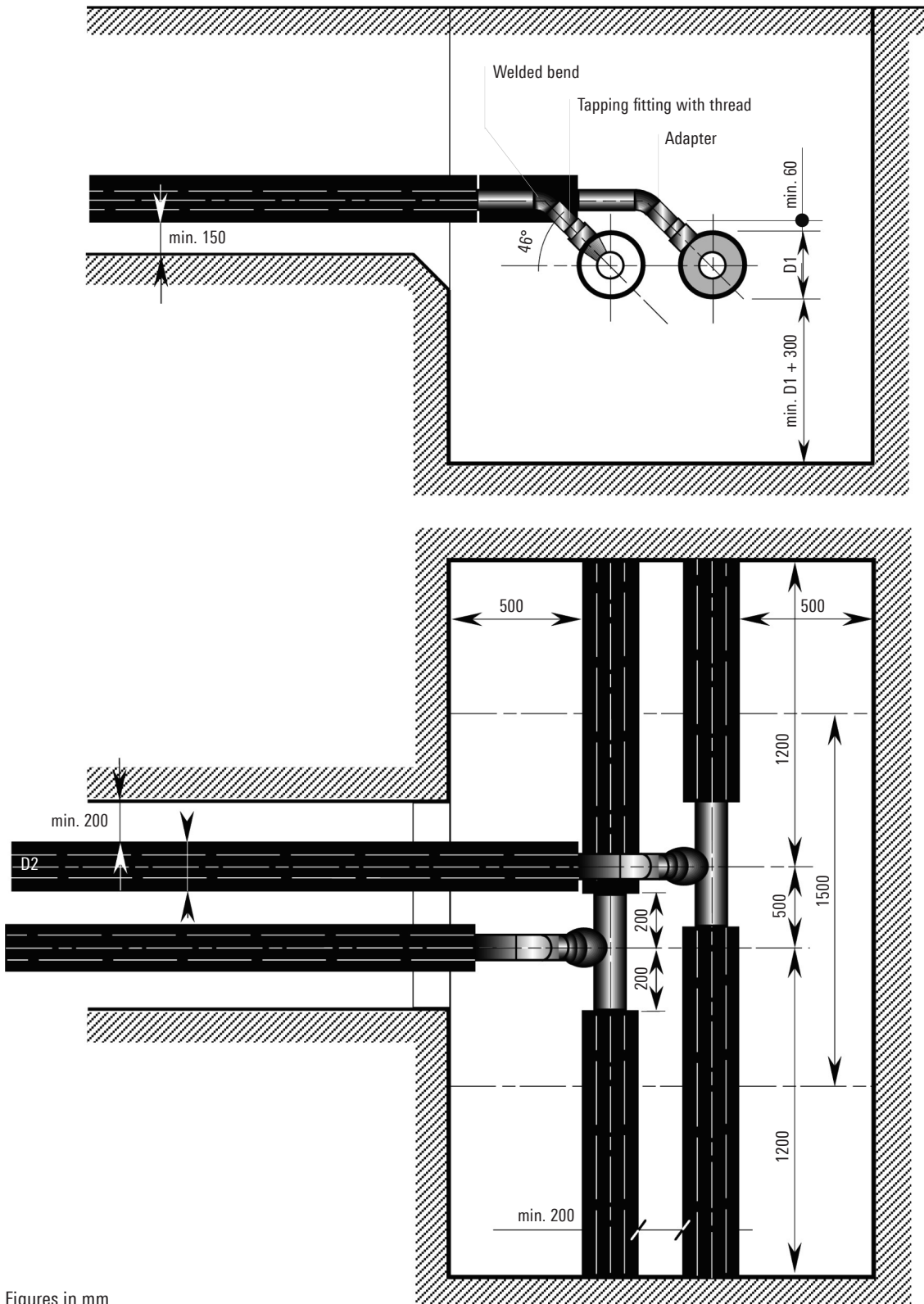

Figures in mm



# Tapping technology

Junction branch at bottom with 45° PRE bend

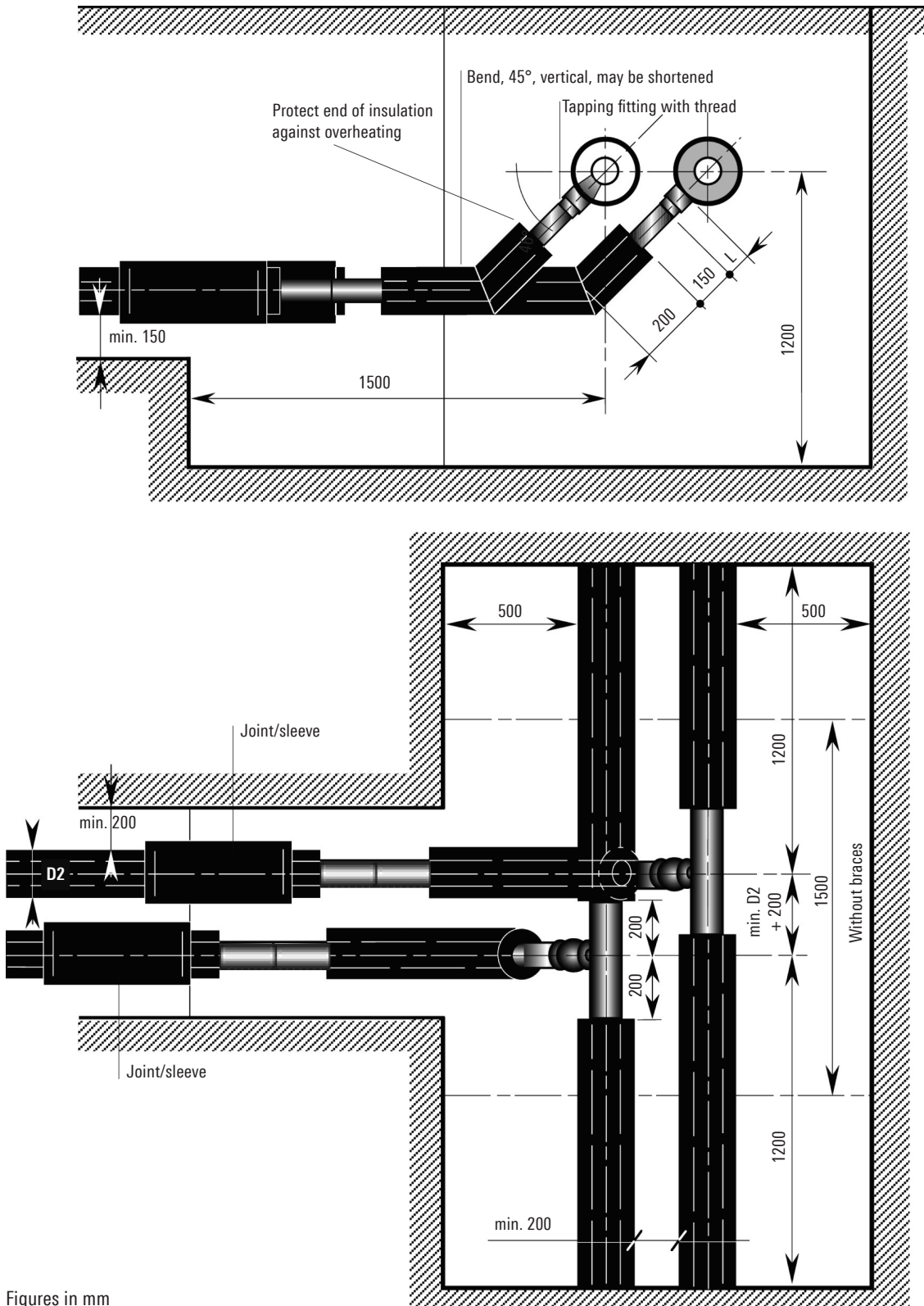

Figures in mm



# Tapping technology

Junction branch at bottom with 45° welded bend

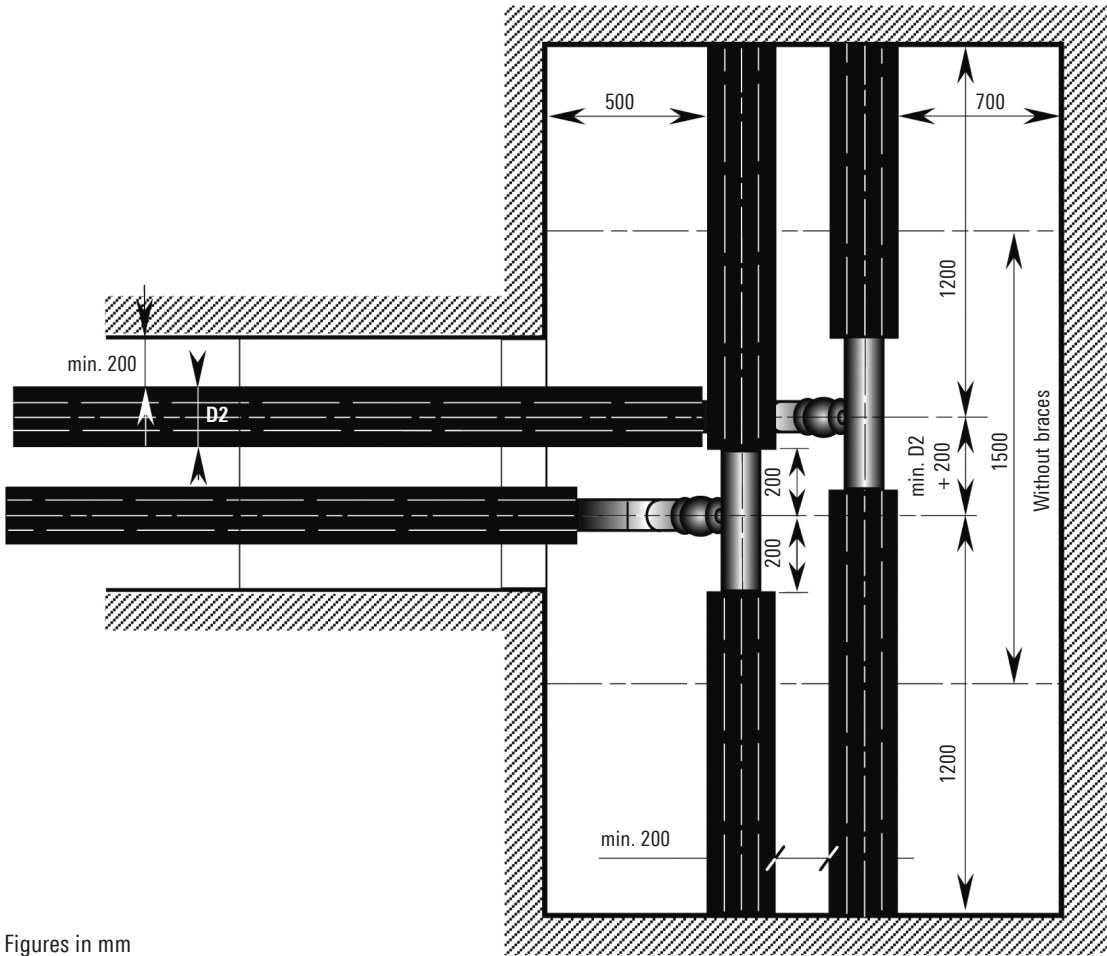
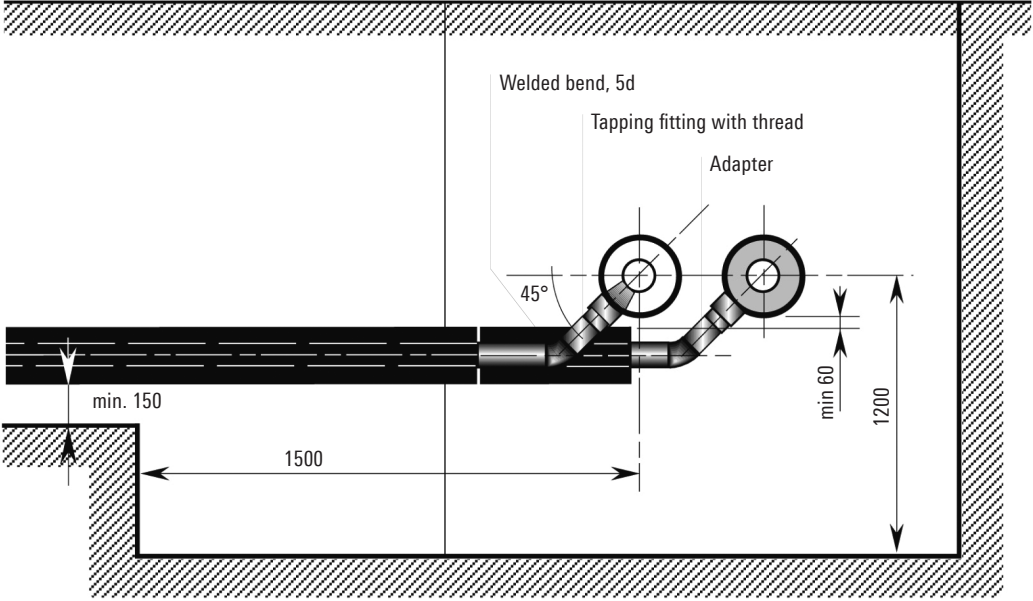

Figures in mm

# Tapping technology

Junction branch at top with 90° PRE bend

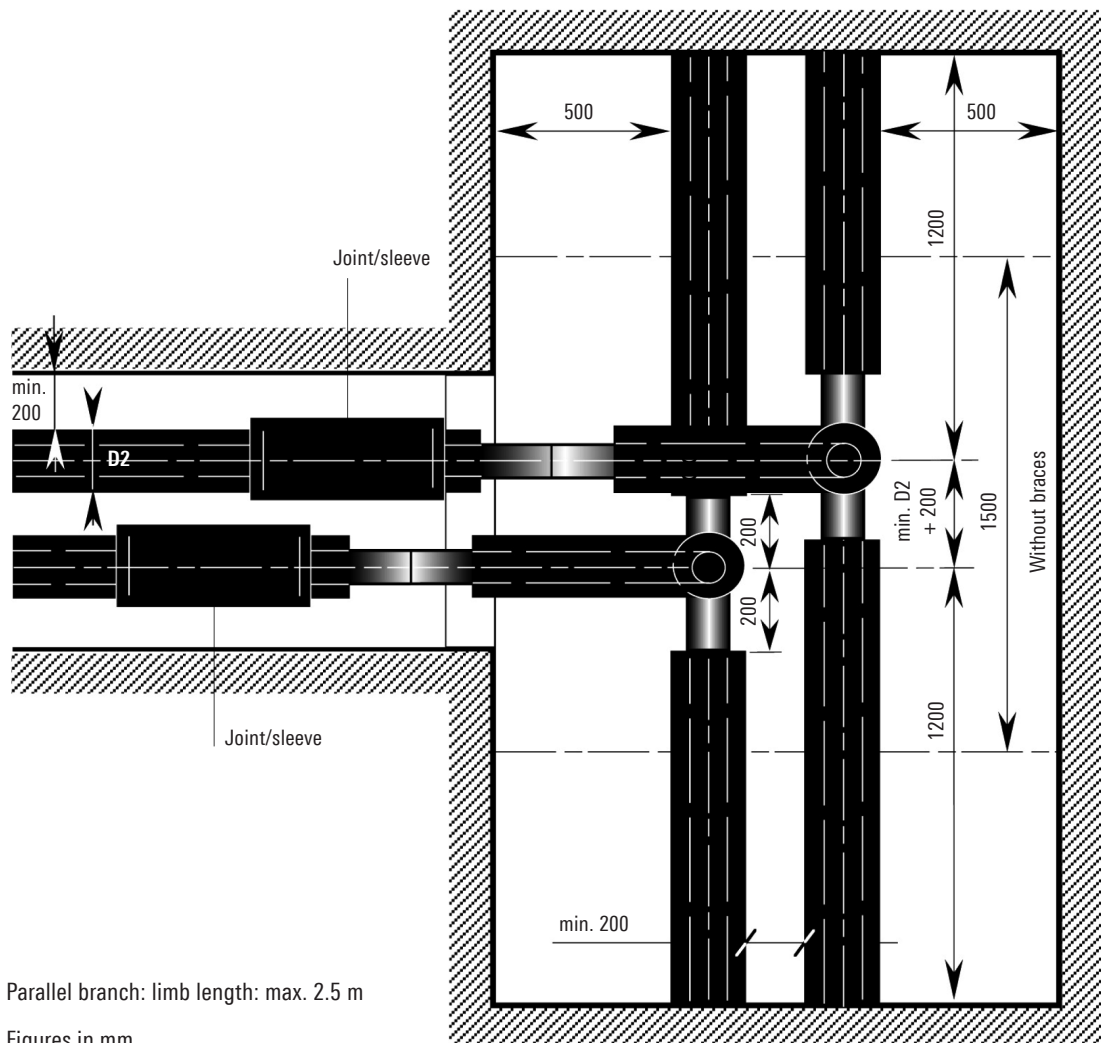
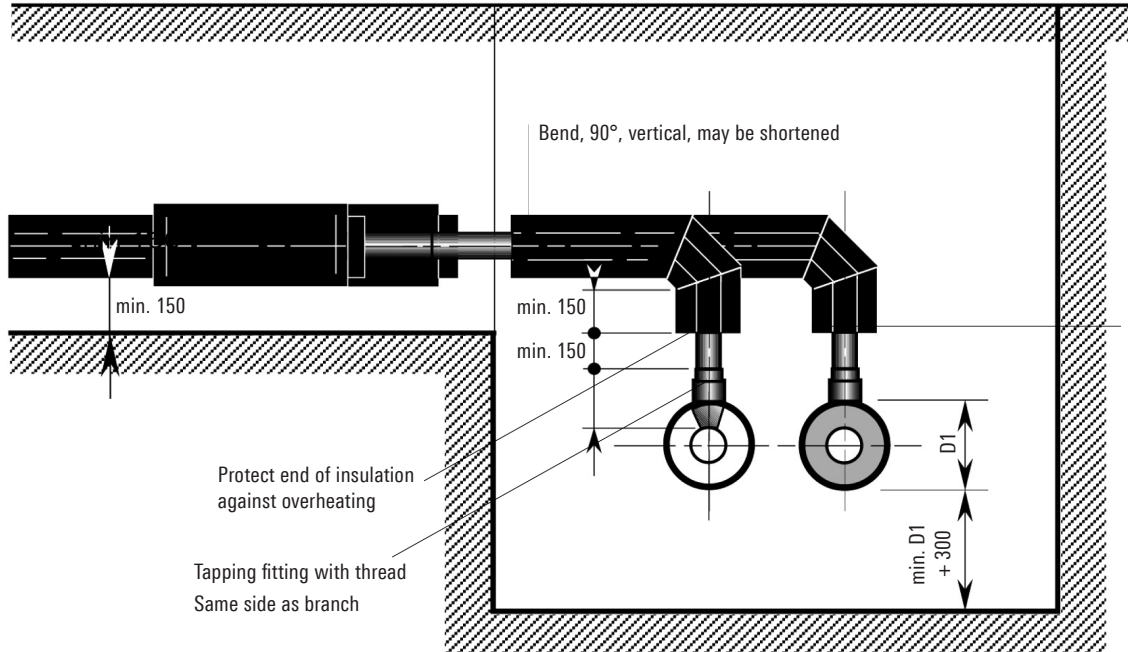

Parallel branch: limb length: max. 2.5 m

Figures in mm